

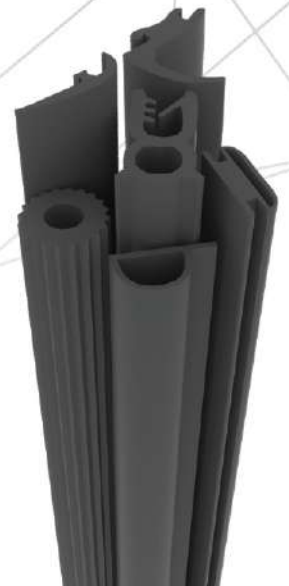

C U S T O M  
D O W N S T R E A M  
S Y S T E M S



*In Line*  
*With Your Future*

[cdsmachines.com](http://cdsmachines.com)

## CDS HISTORY

Founded in Montreal, Canada in 1997, CDS rapidly became recognized for its sturdy, custom-made machinery and customer-dedicated service. From the beginning, CDS' founders, Franco Pecora, who would later pass the leadership baton to his son Antonio, and three other partners, envisioned a company that would set new standards in the extrusion industry for durable and reliable machines, offering expertise according to customers' exact specifications, backed by efficient service.

With over 100 employees, including determined craftsmen, talented engineers, and accomplished professionals, CDS demonstrates its flexibility by meeting the demands of this new global market.

Over two decades later, their vision became a reality. CDS, a family-owned business, has introduced its machinery to different industries and markets around the world, including the United States, Mexico, South America, Europe, the Middle-East, and Asia.

CDS has become a leading manufacturer of downstream plastic extrusion machinery, delivering custom downstream equipment, die tooling, services, and turnkey solutions for polymer and rubber applications including pipes, profiles, tubes, engineering plastics, automotive parts, custom products, and medical tubing.

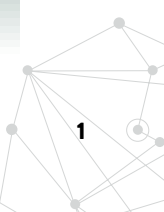

## TABLE OF CONTENTS

<b>ABOUT CDS.....</b>	<b>3</b>
<b>DIE TOOLING.....</b>	<b>7</b>
<b>TURNKEY SYSTEMS.....</b>	<b>9</b>
<b>LINE CONTROL AND AUTOMATION.....</b>	<b>11</b>
<b>OUR PRODUCT CATEGORIES.....</b>	<b>13</b>
Cooling.....	14
Pulling.....	28
Cutting.....	38
Combination Units.....	46
Collection.....	52
Texturizing.....	59
Auxiliary Equipment.....	61
<b>OUR SOLUTIONS.....</b>	<b>66</b>
Profiles.....	67
Pipes.....	68
Rubber.....	69
Automotive.....	70
Tubes.....	71
Medical.....	72
Engineering Plastics.....	73
<b>SERVICES.....</b>	<b>74</b>



## ABOUT US

For more than 20 years, CDS designs, manufactures, and services a complete lines of downstream extrusion machinery for a wide range of polymer and rubber extruded applications. CDS is based in Montreal, Canada and operates a network of Territory Sales Managers in North America and abroad. CDS serves a variety of plastic downstream extrusion processes with custom applications. Our innovativeness and versatility have been demonstrated through our custom extrusion lines. Serving customers with the most unique and out-of-the-ordinary specifications, CDS accepts challenges from a range of technologies and for many thermoplastic and rubber materials.

### OUR MISSION

CDS is committed to continually producing and innovating lasting solutions that will surpass our customers' expectations by setting new industry standards of quality, performance, safety, reliability, and durability for our wide range of products and services through long-term relationships.

### OUR VISION

CDS aims to become the world's leading downstream extrusion manufacturer by engaging its employees to provide technical know-how, advanced technology, creative engineering, and excellent service.

### OUR VALUES

We stand to bring innovation, technology, and expertise to every plastic and rubber extruder processor in the world".



*Our expertise is demonstrated in our process knowledge and the flexibility of our engineering, manufacturing, and service capabilities.*

## OUR EXPERTISE / HOW WE EXCEL

From the first customer interaction until the end of the product life cycle, CDS enters a long-term partnership with its customers in providing a high standard and unique business-to-business relationship. We have forged our reputation by offering our customers:

- QUALITY CONSTRUCTION
- ROBUST MACHINERY
- CUSTOMIZATION
- LONG-LASTING ENGINEERING
- RELIABLE PERFORMANCE
- EASE OF OPERATION
- COMPETITIVE LEAD TIMES



## OUR CAPABILITIES

CDS' extrusion capabilities are classified in the following categories:

1. Die Tooling
2. Turnkey Systems
3. Line Control and Automation
4. Cooling and Sizing
5. Pulling
6. Cutting
7. Combination Units
8. Collection
9. Texturizing
10. Auxiliary Equipment

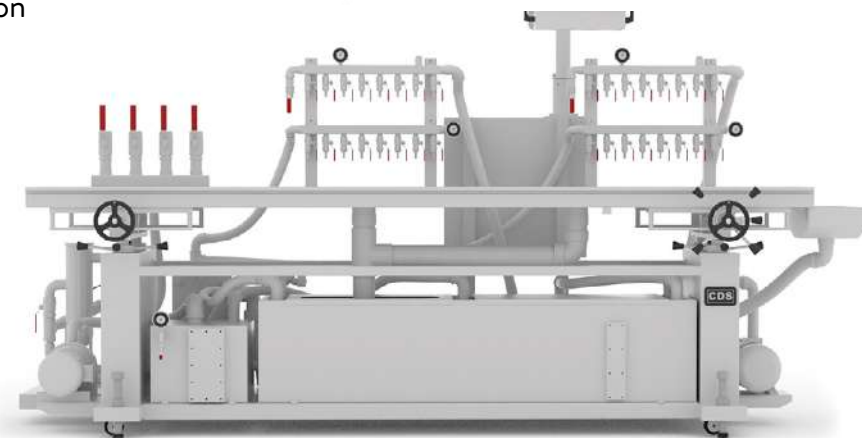

## OUR DOWNSTREAM SOLUTIONS

CDS' machinery and post-extruder systems have been designed according to our customers' specific needs and to provide the best possible solutions for the rubber and plastic extrusion industry.

CDS also serve a variety of plastic downstream extrusion processes with custom applications. Our innovativeness and versatility have been demonstrated through our custom extrusion lines. Serving customers with the most unique and out-of-the-ordinary specifications, CDS accepts challenges from a range of technologies and for many thermoplastic and rubber materials.

Our machinery can also process extruded cables, pultruded shapes, copper, and aluminum materials and have been adapted for the most demanding extrusion applications:

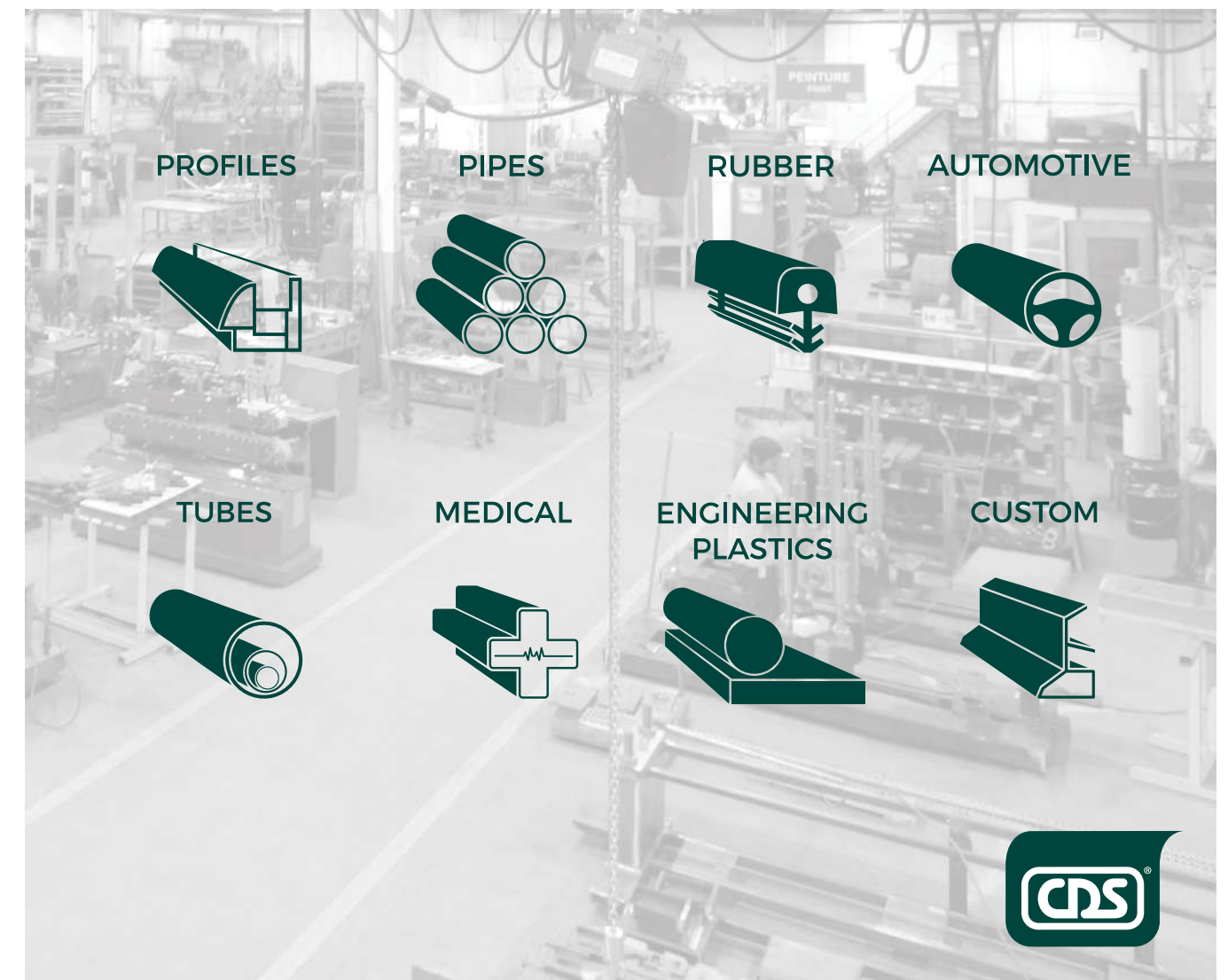

**Note:** The above icons can be found throughout the "Product Categories" section. Please, refer to "Our Solutions" section for more information (Pages 66 - 73)

# OUR PROCESS

From the initial design to the delivery of the final product, our extensive capabilities enable us to produce machinery and systems that meet the precise needs of our customers.

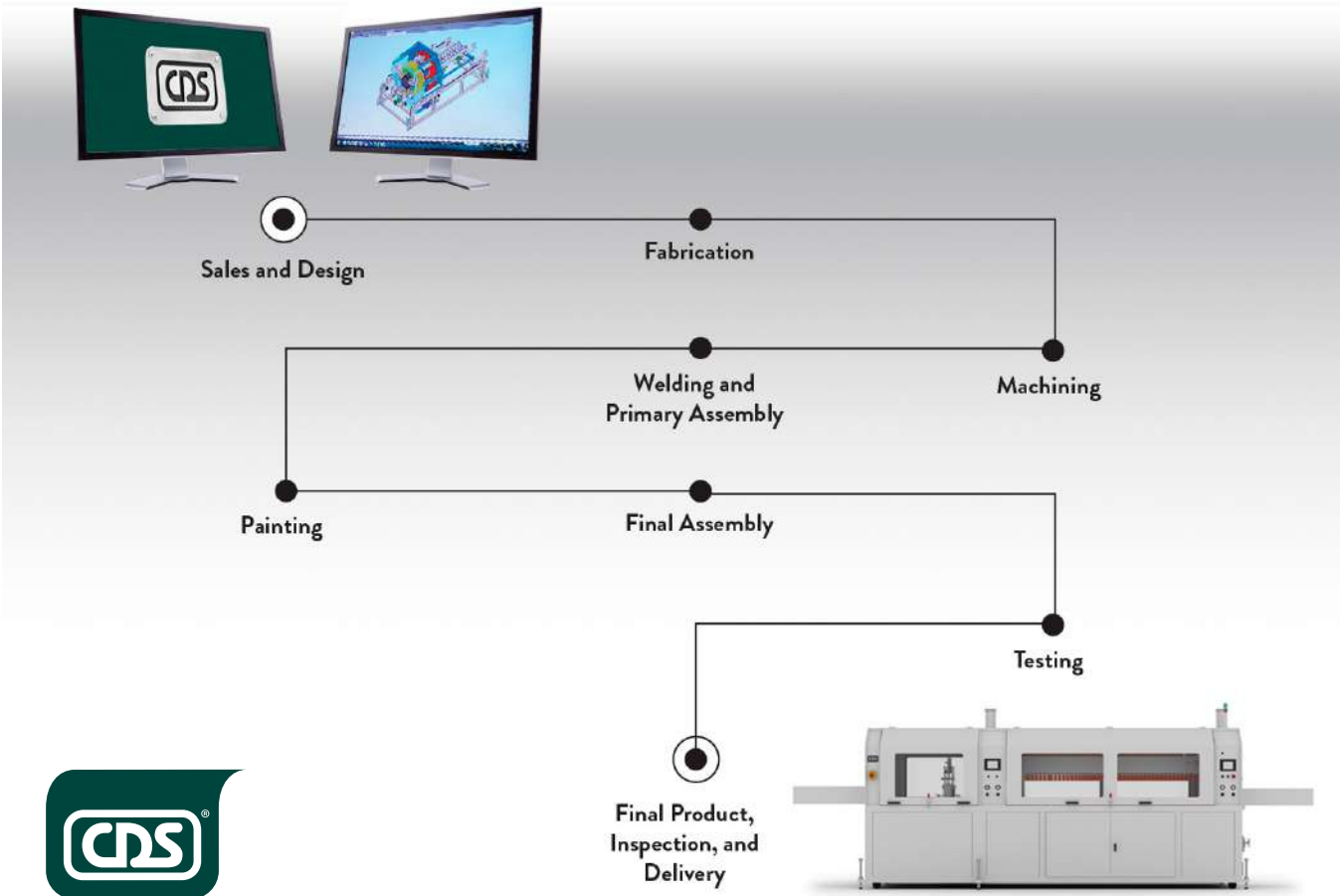

# DIETOOLING

CDS' acquired expertise in Die Tooling enable us to meet the exact product specifications by ensuring accurate designs, superior quality, competence, and innovation using the latest technology.

Thanks to our full-service machine shop and wire cutting capabilities, our commitment is to produce tools, dies, and sizing systems in compliance with the industry's most demanding standards.

Having been in this industry for over two decades has enabled us to develop the know-how of thousands of high performance extrusion tools.

## OUR FEATURES

- ✓ Superior end-product quality
- ✓ High quality output at low operating cost
- ✓ Increased productivity
- ✓ Long-lasting
- ✓ Perfect for round-the-clock production or small production runs
- ✓ Excellent process control
- ✓ Easily upgradable
- ✓ Different options available



## OUR APPLICATIONS

### OUR APPLICATIONS

- Window and door profiles
- Fencing profiles
- Technical profiles
- Foam profiles
- Custom profiles
- Pipes
- Tubes
- Medical tubing
- Rubber extrusions
- Solid rods and sheets
- Hot/Cold dies
- Die plates
- Dry calibrators
- Sizing sleeves and templates
- Heater plates and bands

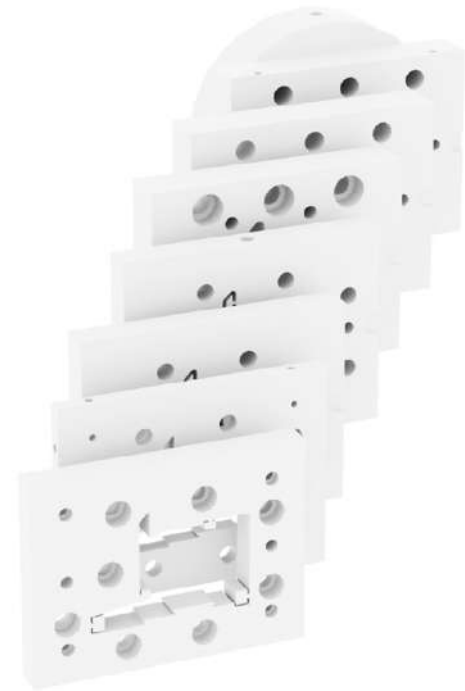

\*Hot die cross section



\*Pipe die with sizing sleeve

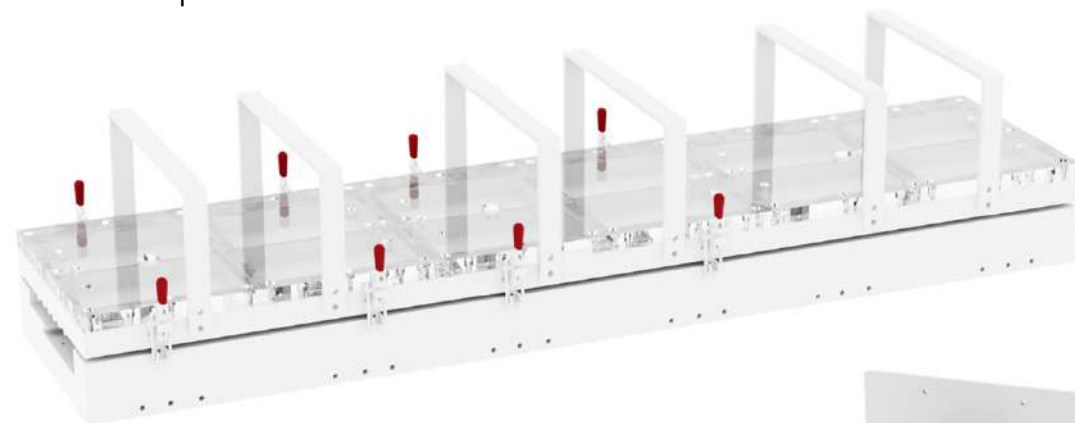

\*Sizing calibrator



\*Hot die and sizing calibrator

## TURNKEY SYSTEMS

CDS' extrusion know-how and continuous improvements in the plastic extrusion industry backed by innovative controls, technology, and process support have positioned CDS as a true Turnkey System provider.

Our expertise is our ability to deliver your project from A to Z. We offer complete custom design systems from conception to the final product. Whether you are a newcomer to the plastic extrusion industry, an extrusion processor who wants to market a new product, or an R&D organization testing lab lines, CDS can furnish complete Turnkey Solutions for your extrusion applications.

### OUR FEATURES

- ✓ End-product design and customization
- ✓ Optimal quality and production output
- ✓ Process knowledge, support and training on every system
- ✓ Run-off, Customer Acceptance Testing, and FAT (Factory Acceptance Testing)
- ✓ Advisory services for machinery maintenance and performance optimization

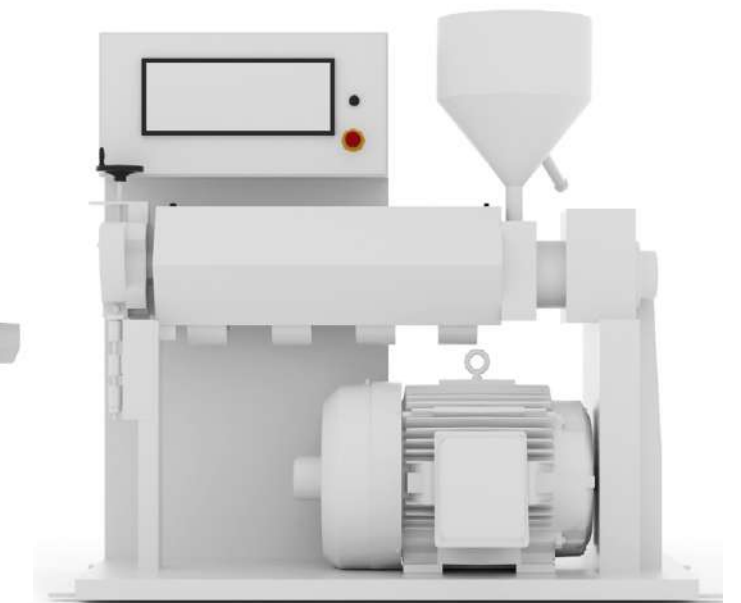
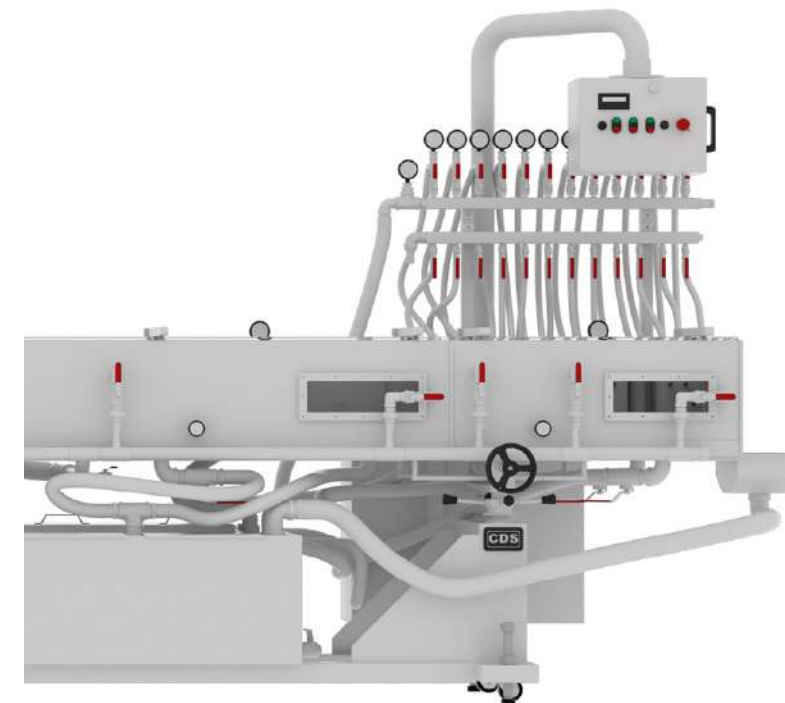

## OUR APPLICATIONS

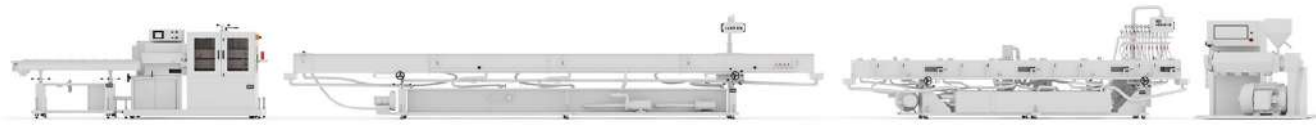

CDS' range of capabilities is as broad as the applications we support including the following:

- Polyolefin and PVC pipes
- Profile and custom profile extrusion
- Wood composites
- Rigid and flexible tubing systems
- Medical tubing
- Automotive tubing and seals
- Industrial hoses and tubes
- Solid rods and sheet extrudates

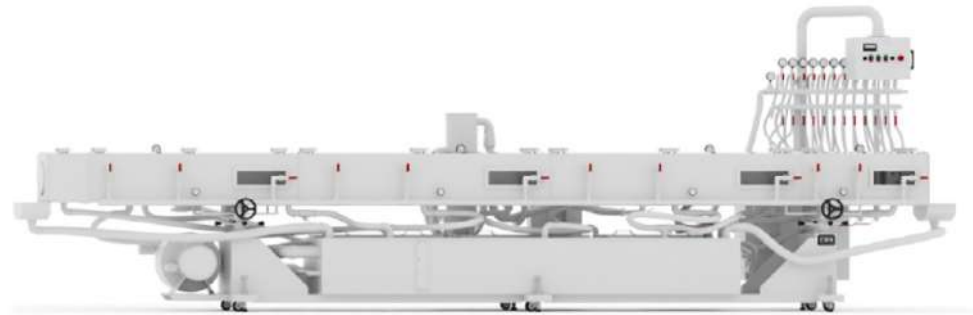
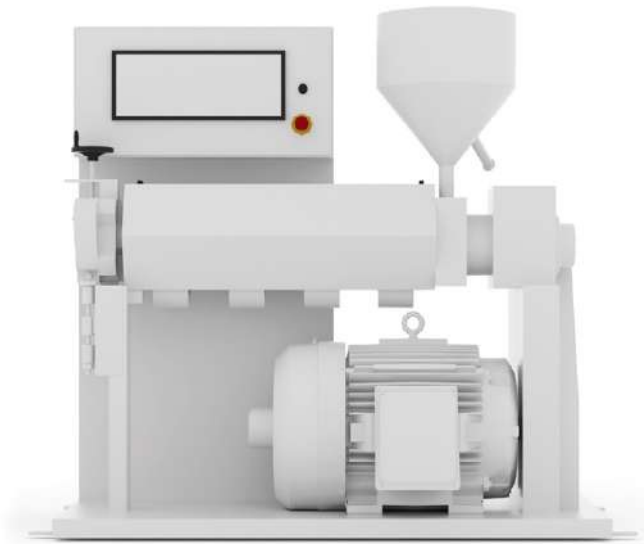

## LINE CONTROL AND AUTOMATION

CDS' machinery includes both a combination of standard features and optional process monitors that can be integrated to your control system architecture and communication networks. Determining the best throughput rate of any extrusion line depends on a series of parameters: effective process temperatures, vacuum levels, pulling torque and speeds, cutting accuracy, and data collection.

### OUR FEATURES

- ✓ Integrates complex extrusion control systems in multiple lines
- ✓ Incorporates robotics and programming to other electrical components
- ✓ Reduces lead times and facilitates overall operations
- ✓ Generates alarms for temperature, pressure, vacuum levels, pulling torque and speed, and cutting loads
- ✓ Machine diagnostics for easy troubleshooting
- ✓ Programs speed transitions at different stages of your process
- ✓ Regulates parameter settings and laser set points and bandwidths
- ✓ Data collection via communication protocols
- ✓ Recipe management
- ✓ Safety PLCs for added flexibility
- ✓ Runs two or more common individual applications simultaneously on a single platform

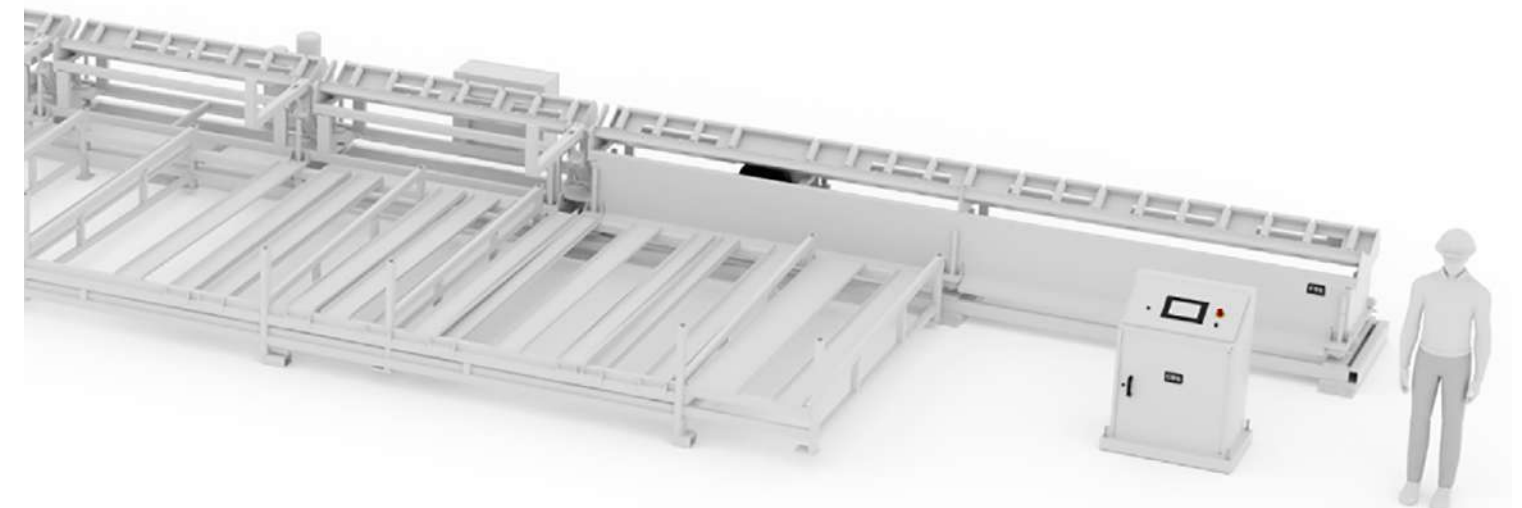

## OUR APPLICATIONS

Each CDS machine in the extrusion line from the extruder to the end of the downstream line is monitored with a combination of hardware and programming controls. Over time, if process parameters drift, alarms will alert the operator and facilitate troubleshooting; thereby ensuring optimal performance of the system at all times.

All controls are user-friendly and our machines have integrated safety controls for the following categories:

- 1 Cool and Size Controls
- 2 Haul-Off Controls
- 3 Cutter and Saw Controls
- 4 Combination Unit Controls
- 5 Collection Equipment Controls

Note: Texturizing and Auxiliary Equipment control package available

### Integrated Master Control System (HMI) for complete line control

Although the automation and control system is optional, it is essential to complete the line control of a Turnkey System. Line system monitoring allows the adjustment of vacuum levels, temperatures, and speeds of an entire extrusion line from one main touch screen.

## OUR PRODUCT CATEGORIES

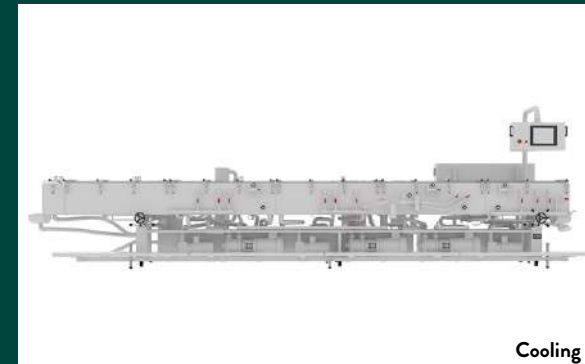

Cooling



Pulling



Cutting

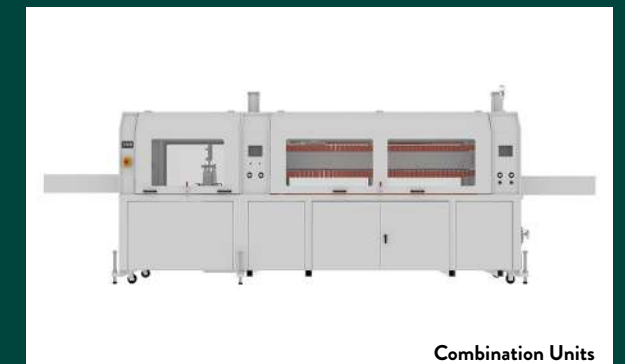

Combination Units

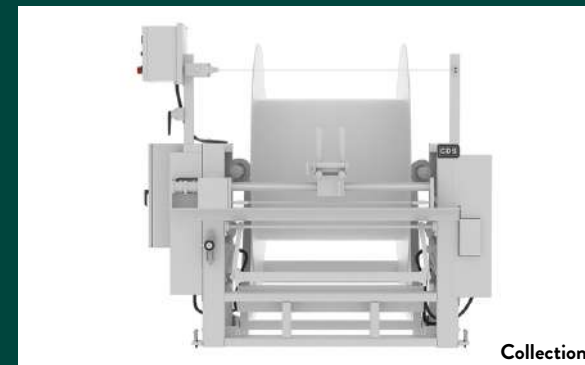

Collection

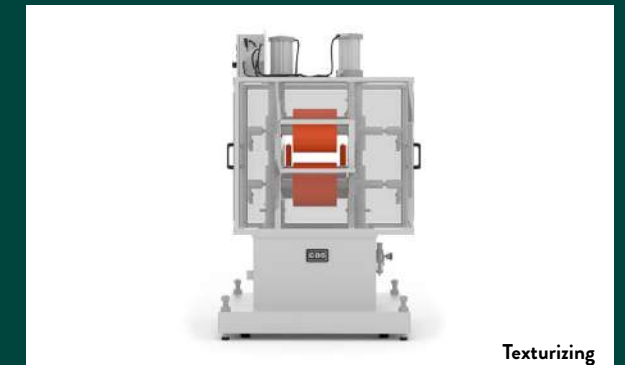

Texturizing



Auxiliary Equipment







## COOLING MACHINES

CDS' Cooling Machines are recognized for their customized calibration tables, vacuum and sizing tanks, drum coolers, and air cooling tables, which cool and size extruded materials using vacuum, flood, spray, forced air, or a combination of all.

### CALIBRATION TABLES

CDS' Vacuum Calibration Tables provide a flexible platform for sizing various polymer profiles. The unit's mounting rails can accommodate calibration tooling and an auxiliary tank, both of which can be supplied with controllable vacuum and water cooling.



#### Standard Specifications:

- Stainless steel components to prevent corrosion and water contamination
- T-slot mounting rails for calibration tooling or auxiliary tanks
- Vacuum and Water manifolds
- Service step
- Motorized longitudinal movement and height adjustment
- 3-axis table movement for precise alignment with the extrusion line
- Line direction: Right-Left/Left-Right

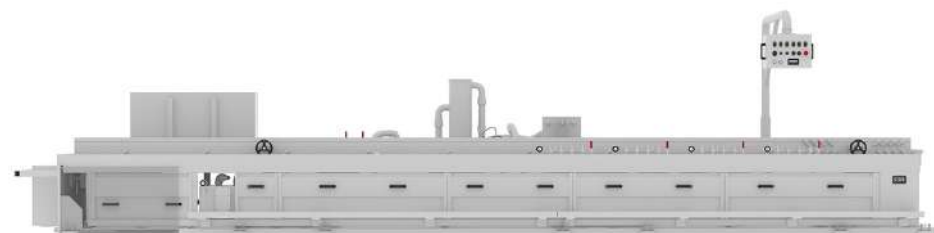

### VACUUM CALIBRATION TABLES

CDS' Vacuum Calibration Tables provide dry sizing for various profile applications. They can be customized with closed-loop water recirculation systems and/or auxiliary tanks.

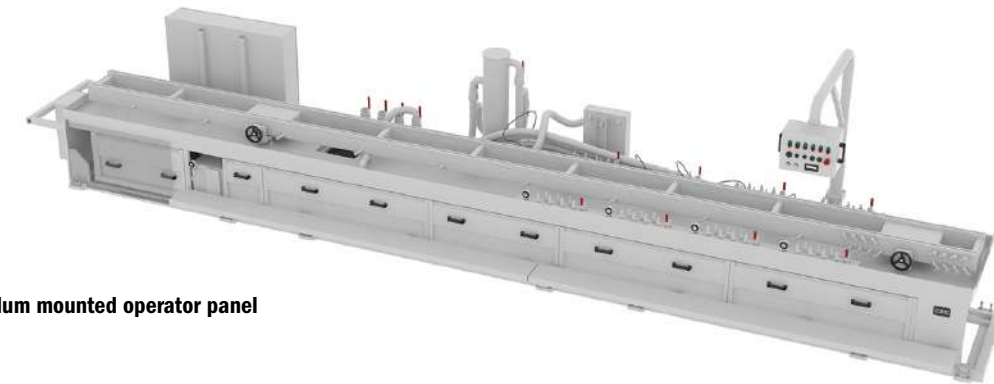

✓ Pendulum mounted operator panel

#### CVC SERIES

STANDARD FEATURES	CVC60	CVC80	CVC100	CVC120	CVC140	CVC160	CVC180	CVC230	CVC280	CVC340	CVC420	CVC500	CVC750
Table Length	6'	8'	10'	12'	14'	16'	18'	23'	28'	34'	42'	50'	75'
Table Width	Up to 40"												

\*CVC: CDS Vacuum Calibration Table

### ENERGY-EFFICIENT VACUUM CALIBRATION TABLES

CDS' Energy-Efficient Vacuum Calibration Tables are recognized for their energy saving system and offer a long-term cost effective solution.

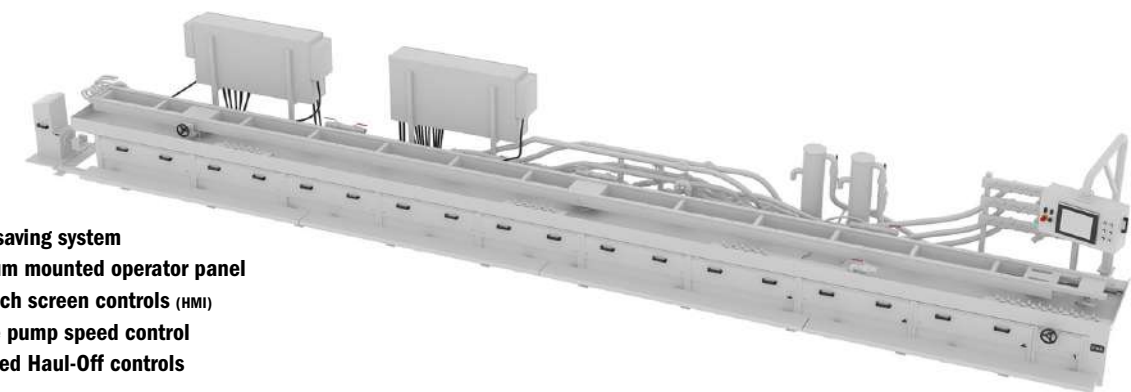

- ✓ Energy saving system
- ✓ Pendulum mounted operator panel with touch screen controls (HMI)
- ✓ Variable pump speed control
- ✓ Integrated Haul-Off controls

#### CVCE SERIES

STANDARD FEATURES	CVCE100	CVCE120	CVCE140	CVCE160	CVCE180	CVCE230	CVCE280	CVCE340	CVCE420	CVCE500	CVCE750
Table Length	10'	12'	14'	16'	18'	23'	28'	34'	42'	50'	75'
Table Width	Up to 40"										

\*CVCE: CDS Energy-Efficient Vacuum Calibration Table

TANKS

CDS Cooling Tanks come in a variety of sizes and can be equipped with a closed-loop water recirculation system that minimizes water consumption, accompanied by stainless steel components to prevent corrosion and water contamination. Each compartment is designed to customers' specifications, allowing maximum flexibility and control. Steady vacuum controls are offered together with value-added options which can be incorporated to maximize cooling efficiency and production output.

VACUUM TANKS

CDS' Vacuum Tanks are recognized for their stable vacuum and precise cooling capabilities for a variety of profile, pipe and tube applications by using vacuum, spray, or a combination of both. A wide range of value-added options can be chosen to maximize cooling efficiency.

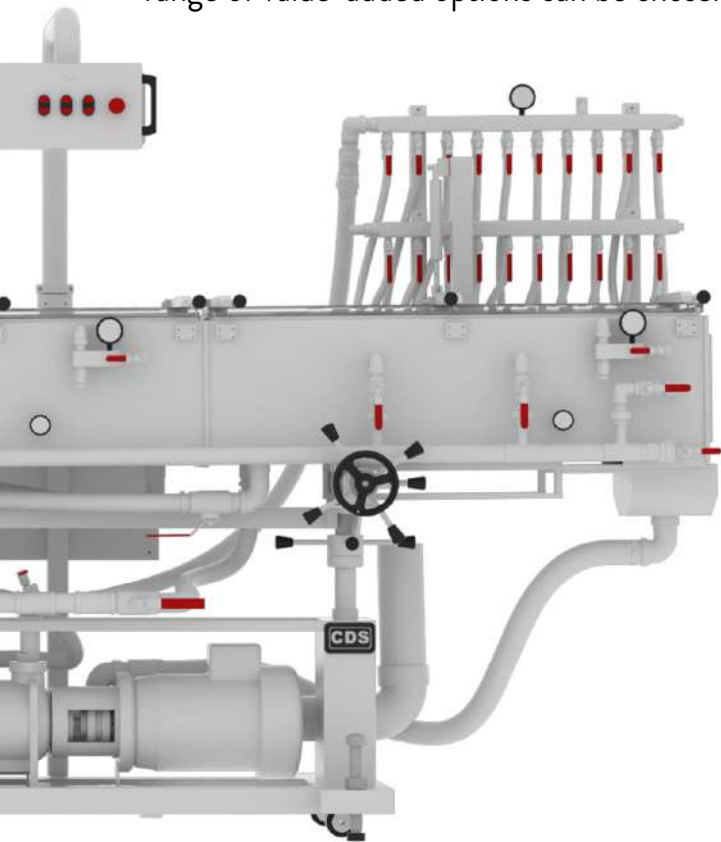

Standard Specifications:

- Heavy-duty steel construction
- Stainless steel upper tanks and reservoirs
- Front or pendulum mounted operator panel
- Water level control
- Product support rollers
- Vacuum and/or flood capabilities
- 3-axis movement for precise alignment with the extrusion line
- Line direction: Right-Left/Left-Right

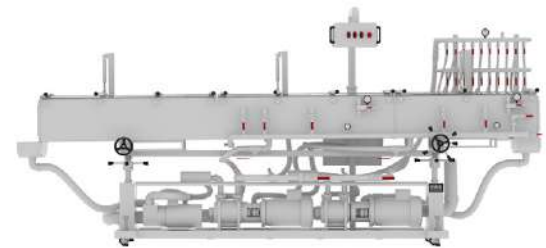

VACUUM SIZING TANKS

CVS SERIES

STANDARD FEATURES	CVS8	CVS10	CVS12	CVS14	CVS16	CVS18	CVS20	CVS22	CVS24
Tank Cross Section	8" x 8"	10" x 10"	12" x 12"	14" x 14"	16" x 16"	18" x 18"	20" x 20"	22" x 22"	24" x 24"
Tank Length	Up to 30'								
O.D. Capacity	1"	2"	3"	4"	4"	6"	8"	10"	12"

\*CVS: CDS Vacuum Sizing Tank

HIGH PRECISION VACUUM SIZING TANKS

CPVS SERIES

STANDARD FEATURES	CPVS6	CPVS8	CPVS12	CPVS14	CPVS16
Tank Cross Section	6" x 6"	8" x 8"	12" x 12"	14" x 14"	16" x 16"
Tank Length	Up to 30'				
O.D. Capacity	1"	2"	3"	4"	6"

\*CPVS: CDS High Precision Vacuum Sizing Tank

- ✓ Spray or water turbulence bars
- ✓ Tempered glass lids
- ✓ High-efficiency closed loop vacuum control system
- ✓ Touch screen controls (HMI)
- ✓ Vacuum levels: 0-130 inches of H<sub>2</sub>O or 0-200 inches of H<sub>2</sub>O

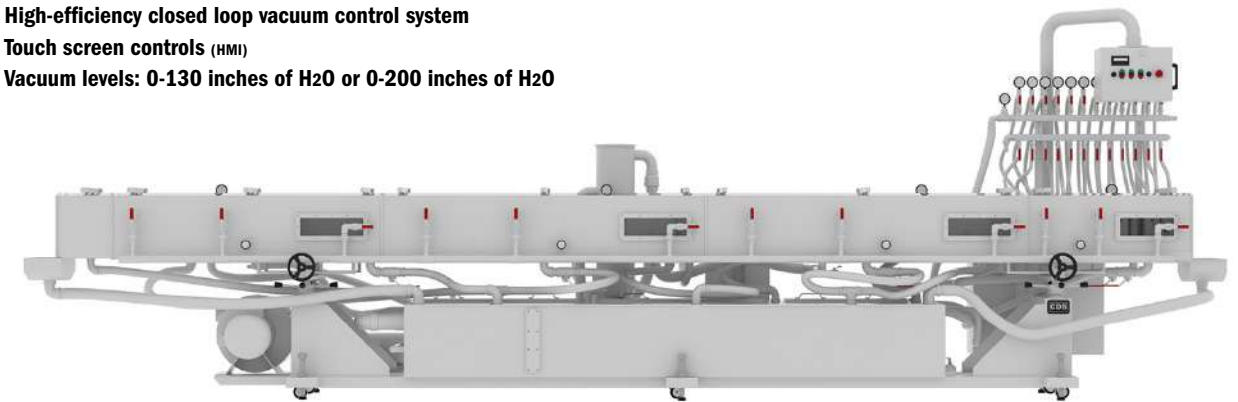

VACUUM SPRAY SIZING TANKS

CVSS SERIES

STANDARD FEATURES	CVSS8	CVSS10	CVSS12	CVSS14	CVSS16	CVSS20	CVSS24	CVSS30	CVSS36
Tank Cross Section	8" x 8"	10" x 10"	12" x 12"	14" x 14"	16" x 16"	20" x 20"	24" x 24"	30" x 30"	36" x 36"
Tank Length	Up to 30'								
O.D. Capacity	1"	2"	3"	4"	6"	10"	12"	20"	24"

\*CVSS: CDS Vacuum Spray Sizing Tank

- ✓ Stainless steel spray bars with quick-change spray nozzles
- ✓ Hinged safety clear-view lids
- ✓ Vacuum, spray and/or flood capabilities

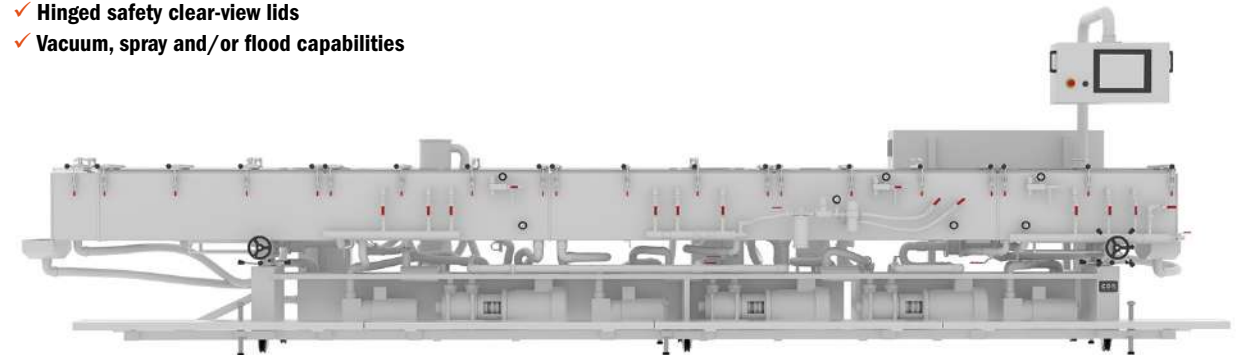

DODECAGONAL VACUUM SPRAY SIZING TANKS

CVSSD SERIES



STANDARD FEATURES	CVSSD16	CVSSD20	CVSSD24	CVSSD30	CVSSD36	CVSSD40
Tank Cross Section	16" x 16"	20" x 20"	24" x 24"	30" x 30"	36" x 36"	40" x 40"
Tank Length	Up to 30'					
O.D. Capacity	6"	10"	12"	18"	24"	30"

\*CVSSD: CDS Dodecagonal Vacuum Spray Sizing Tank

- ✓ Stainless steel spray bars with quick-change spray nozzles
- ✓ Hinged safety clear-view lids
- ✓ Vacuum, spray and/or flood capabilities

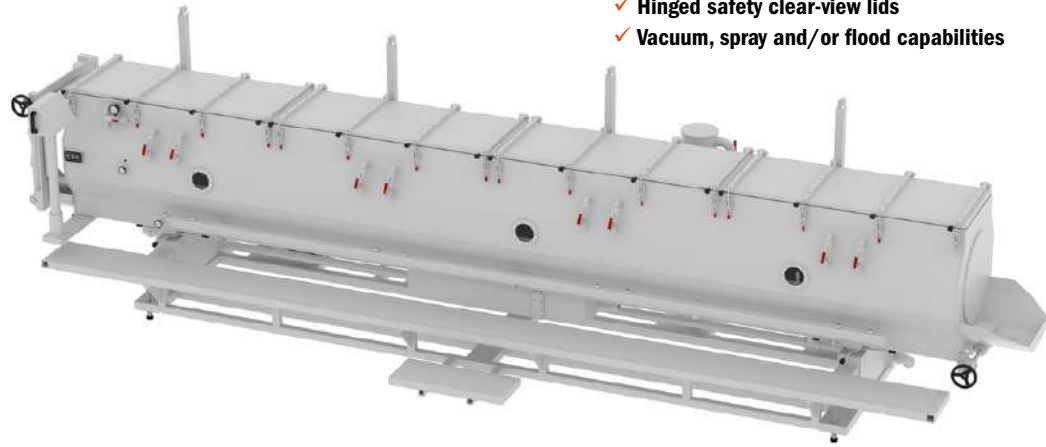

ROUND VACUUM SPRAY SIZING TANKS

CVSS-R SERIES



STANDARD FEATURES	CVSS-R48	CVSS-R60	CVSS-R72
Tank O.D.	48"	60"	72"
Tank Length	Up to 30'		
O.D. Capacity	36"	48"	60"

\*CVSS-R: CDS Round Vacuum Spray Sizing Tank



- ✓ Stainless steel spray bars with quick-change spray nozzles
- ✓ Hinged safety clear-view lids
- ✓ Vacuum, spray and/or flood capabilities

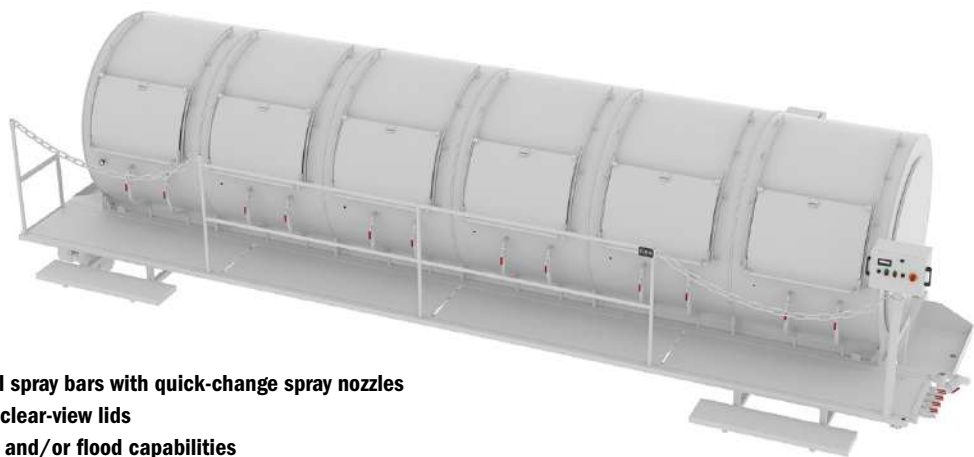

SPRAY TANKS

CDS' Spray Cooling Tanks offer an effective alternative to flood cooling thanks to its full coverage high-pressure spray by utilizing a smaller footprint.

Standard Specifications:

- Heavy-duty steel construction
- Stainless steel upper tanks, reservoirs, and spray bars
- Stainless steel spray bars with quick-change nozzles
- Hinged safety clear-view lids
- Front or pendulum mounted operator panel
- Product support rollers
- Spray capabilities
- 3-axis movement for precise alignment with the extrusion line
- Line direction: Right-Left/Left-Right

- ✓ Stainless steel spray bars with quick-change spray nozzles
- ✓ Hinged safety clear-view lids (Applicable only on \*CST/\*CHST Series)
- ✓ Clear-view curtains for easy access (Applicable only on \*CSTC Series)
- ✓ Up to 60" Pipe/Tube diameters (Applicable only on \*CSTC Series)

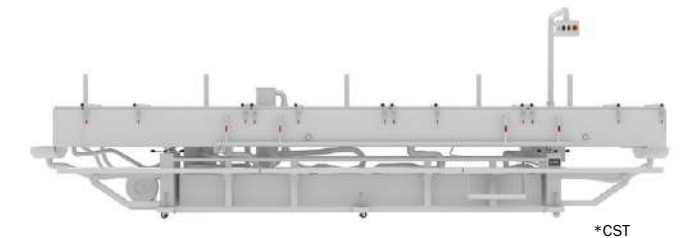

\*CST

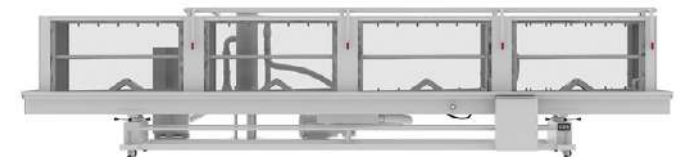

\*CSTC

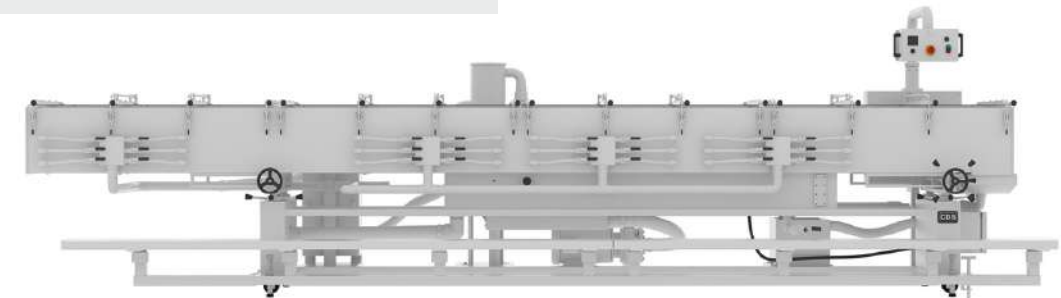

\*CHST

SPRAY COOLING TANKS

CST/CSTC/CHST SERIES



STANDARD FEATURES	CST8	CST10	CST12	CST14	CST18	CST20	CST24	CST36	CST40	CST48	CST60	CST72
Tank Cross Section	8" x 8"	10" x 10"	12" x 12"	14" x 14"	18" x 18"	20" x 20"	24" x 24"	36" x 36"	40" x 40"	48" x 48"	60" x 60"	72" x 72"
Tank Length	Up to 30'											
O.D. Capacity	1"	2"	3"	4"	6"	8"	12"	24"	30"	36"	48"	60"

\*CST: CDS Spray Cooling Tank  
 \*CSTC: CDS Curtains Spray Cooling Tank  
 \*CHST: CDS High Volume Spray Cooling Tank

CONVEYORIZED SPRAY COOLING TANKS

- Stainless steel or plastic conveyor system
- Variable speed control system

\*CCST: CDS Conveyorized Spray Cooling Tank  
 Note: Different sizes available upon request

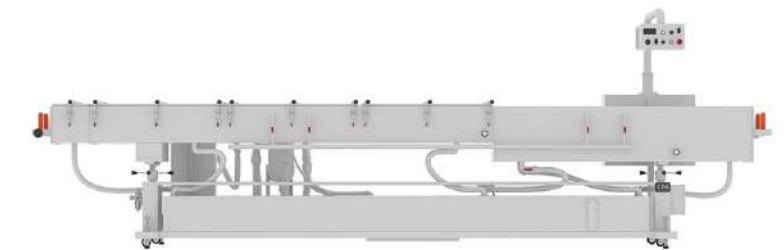

**WATER COOLING TANKS**

CDS' Series of Water Cooling Tanks have been designed with efficient water turbulence to maintain optimal water temperatures for a cost-effective cooling solution.

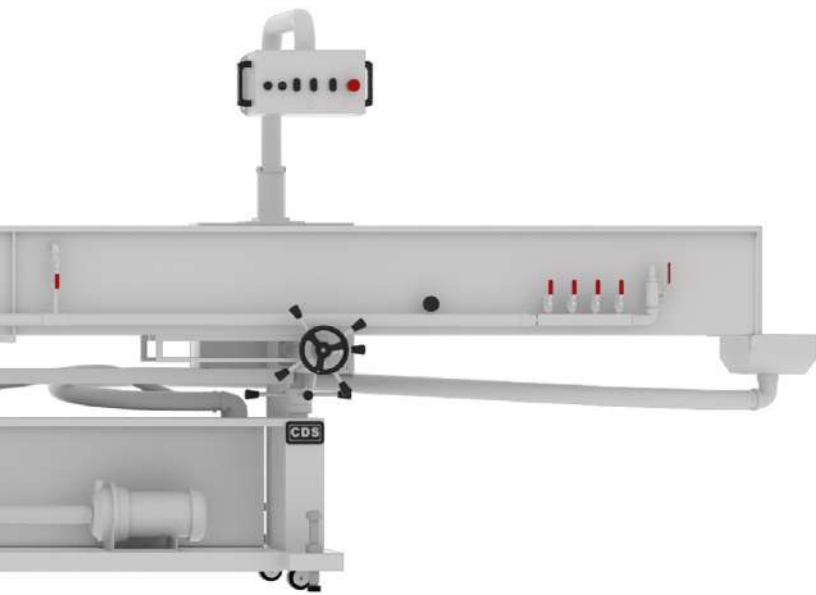

- Standard Specifications:**
- Open upper tank for easy start-up
  - Heavy-duty steel construction
  - Stainless steel upper tanks and reservoirs
  - Front or pendulum mounted operator panel
  - Water level control
  - Water turbulence bars
  - Product support rollers
  - Flood capabilities
  - 3-axis movement for precise alignment with the extrusion line
  - Line direction: Right-Left/Left-Right



**WATER COOLING TANKS**

**CWT SERIES**



STANDARD FEATURES	CWT4	CWT8	CWT10	CWT12	CWT14	CWT16	CWT18	CWT20	CWT22	CWT24
Tank Cross Section	4" x 4"	8" x 8"	10" x 10"	12" x 12"	14" x 14"	16" x 16"	18" x 18"	20" x 20"	22" x 22"	24" x 24"
Tank Length	Up to 30'									
O.D. Capacity	1"	1"	2"	3"	4"	4"	6"	8"	10"	12"

\*CWT: CDS Water Cooling Tank



**MULTI-PASS WATER COOLING TANKS**

- Driven/free-driven sheave(s)
- Variable speed control system

\*CWTM: CDS Multi-Pass Water Cooling Tank  
 Note: Different sizes available upon request



**U-SHAPED WATER COOLING TANKS**

- Driven/free-driven stainless steel wheel
- U-shaped configuration

\*CUWT: CDS U-Shaped Water Cooling Tank  
 Note: Different sizes available upon request

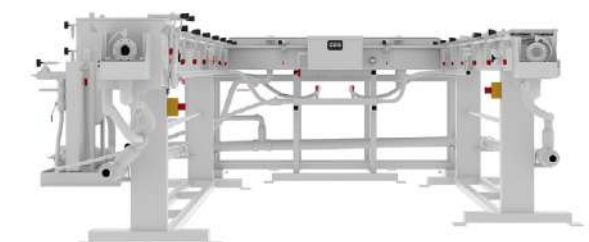
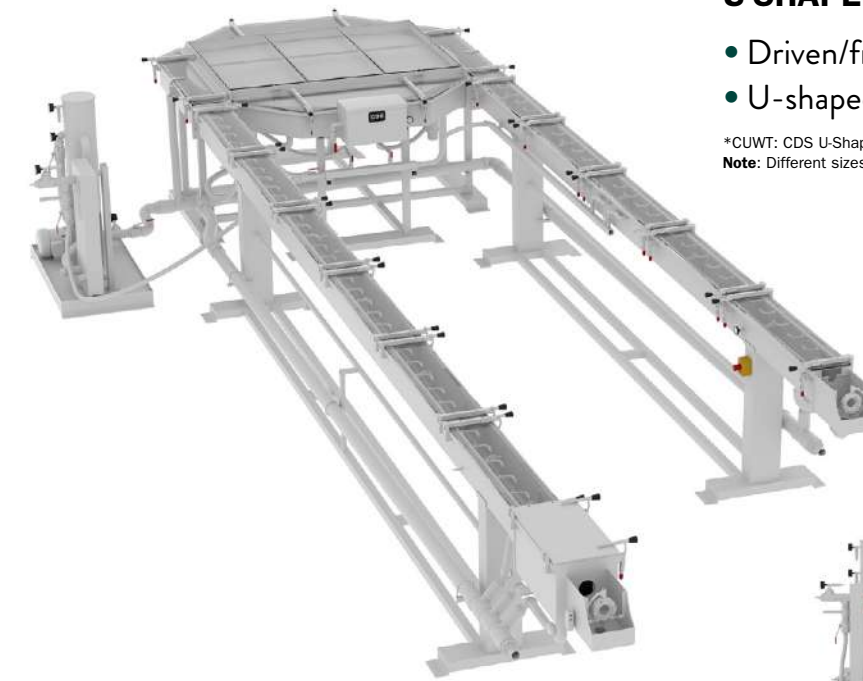

**MEDICAL TANKS**

CDS offers its Series of Medical Tanks that are built on medical grade stainless steel components, are recognized for their High Precision Vacuum Sizing and Cooling Tanks uniquely designed to meet your cooling needs and to provide optimal cooling solutions for a wide range of medical tubing applications.

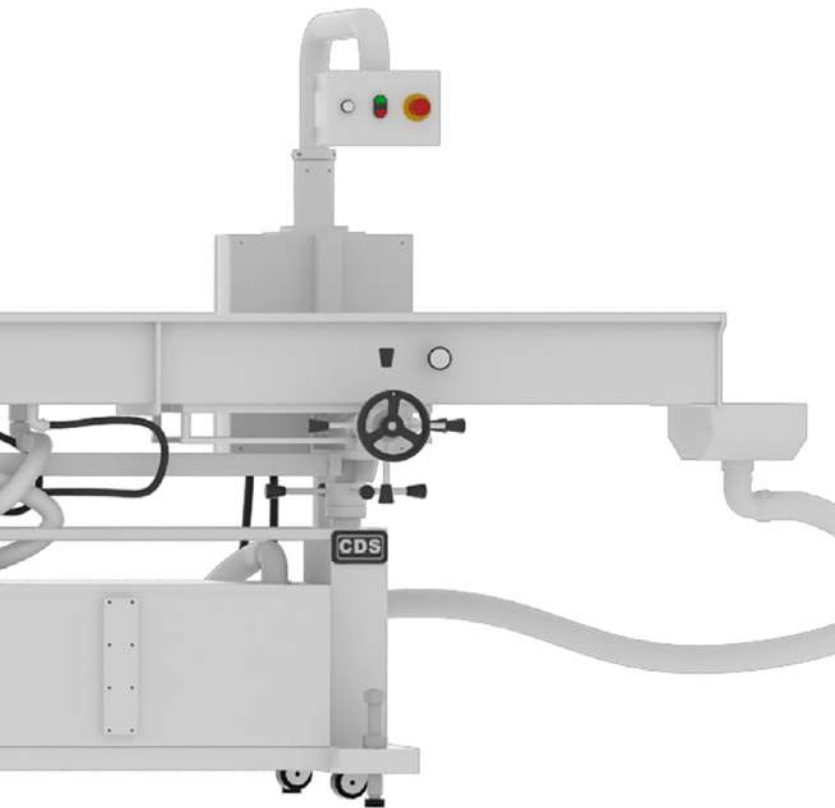

**Standard Specifications:**

- Clean room ready
- Medical grade stainless steel components
- Easy operator clean out, sterilization, and designed for low maintenance
- Steel frame construction
- Stainless steel upper tanks and reservoirs
- Front or pendulum mounted operator panel
- Water level control
- Stainless steel water turbulence bars
- Product support rollers
- 3-axis movement for precise alignment with the extrusion line
- Line direction: Right-Left/Left-Right

**MEDICAL WATER COOLING TANKS**

**CMWT SERIES**

STANDARD FEATURES	CMWT
Tank Length	Up to 30'
O.D. Capacity	Micro up to 2"

\*CMWT: CDS Medical Water Cooling Tank



✓ Open upper tank for easy start-up



**MEDICAL FREE EXTRUSION WATER TANKS**

**CMFEWT SERIES**

STANDARD FEATURES	CMFEWT
Tank Length	Up to 30'
O.D. Capacity	Micro up to 2"

\*CMFEWT: CDS Medical Free Extrusion Water Tank

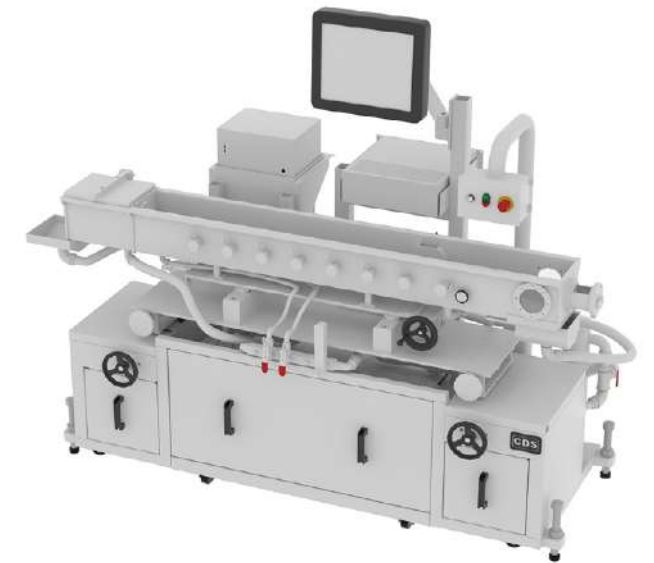

- ✓ Driven/free-driven sheave(s)
- ✓ Variable speed control system
- ✓ Touch screen controls (HMI)

**MEDICAL MULTI-PASS WATER COOLING TANKS**

**CMWTM SERIES**

STANDARD FEATURES	CMWTM
Tank Length	Up to 26'
Number of passes	Up to 5
O.D. Capacity	Micro up to 0.5"

\*CMWTM: CD  
Note: Differen

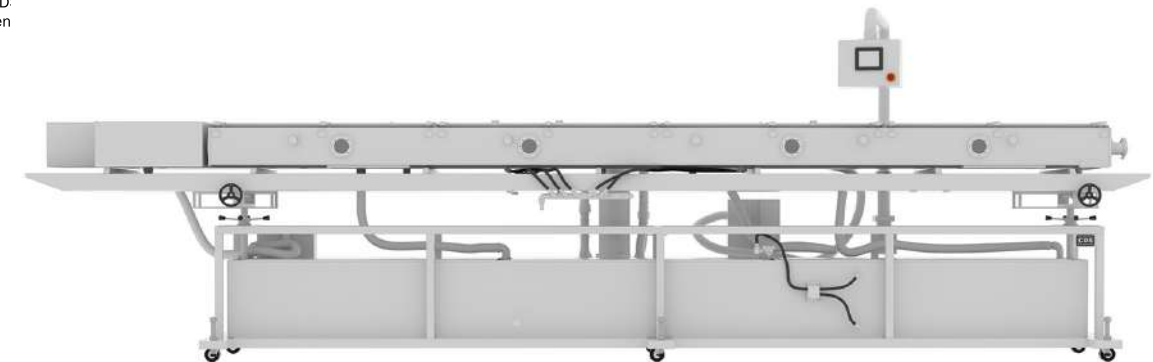

**MEDICAL HIGH-PRECISION VACUUM SIZING TANKS**

**CMPVS SERIES**

STANDARD FEATURES	CMPVS
Tank Length	4' to 26'
O.D. Capacity	Micro up to 2"

\*CMPVS: CDS Medical High Precision Vacuum Sizing Tank

- ✓ Vacuum and/or flood capabilities
- ✓ Tempered glass lids
- ✓ High-efficiency closed loop vacuum control system
- ✓ Touch screen controls (HMI)
- ✓ Vacuum levels: 0-130 inches of H<sub>2</sub>O or 0-200 inches of H<sub>2</sub>O



**MULTI-PASS DRUM COOLERS**

CDS' Drum Coolers are designed in a variety of widths and lengths with a small footprint to provide a compact and customized option for your specific cooling needs.



**Standard Specifications:**

- Heavy-duty steel construction
- Stainless steel driven/free-driven drums
- Variable speed control system
- Guide roller system for product tracking
- Vertical or horizontal drum orientation
- Line direction: Right-Left/Left-Right



**VERTICAL DRUM COOLERS**

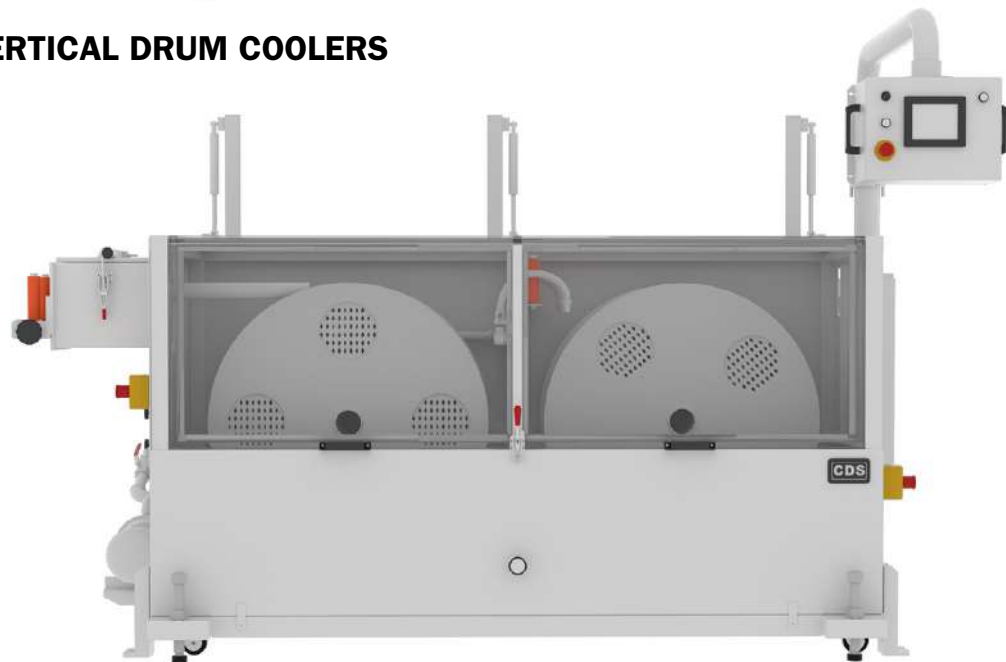

**HORIZONTAL DRUM COOLERS**

**AIR COOLING TABLES**

CDS' Air Cooling Tables are recognized for their solid construction and can be easily positioned to the height of the extrusion line. They provide efficient cooling for profiles with fully adjustable air blowers and nozzles.

**Standard Specifications:**

- Heavy-duty steel construction
- Vertical height adjustment
- Air nozzles with adjacent height and angle positioning
- Sizing plates or fixed rollers
- Fixed or variable speed air blowers

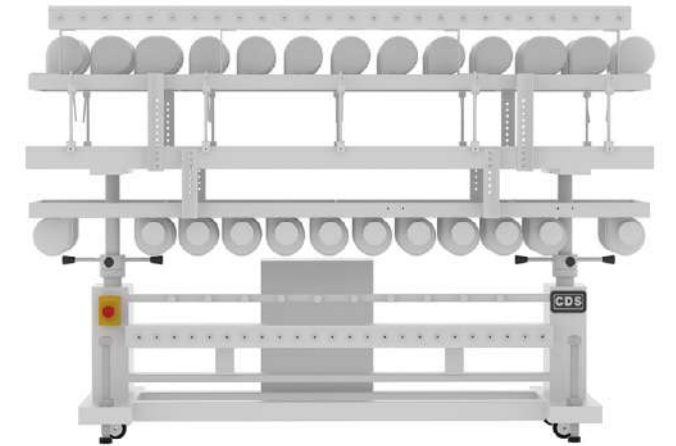

**AIR COOLING TABLES (FIXED)**

CDS' Air Cooling Tables provide efficient cooling for profiles with fixed air blowers and nozzles.

CAT: CDS Air Cooling Table

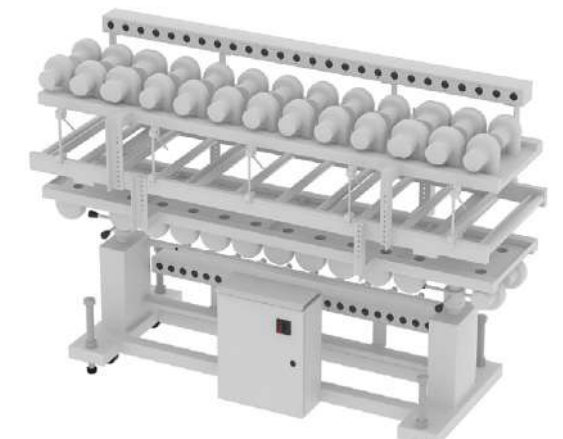

✓ Customizable fixed blowers

**PROFILE AIR COOLING TABLES (ADJUSTABLE)**

CDS' Profile Air Cooling Tables provide efficient cooling for profiles with fully adjustable air blowers and nozzles.

CAC: CDS Profile Air Cooling Table

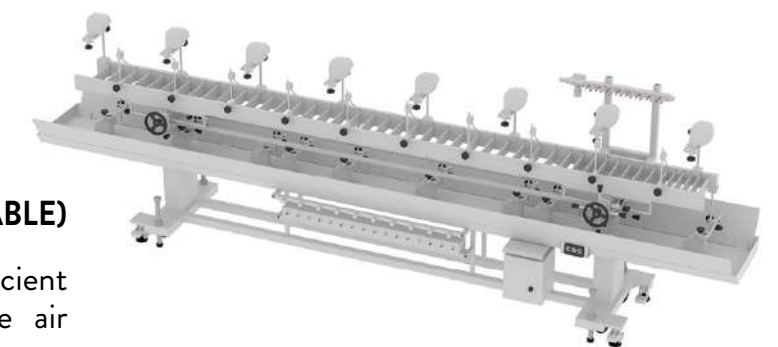

✓ Customizable adjustable blowers

**COOLING OPTIONS**

- Dual or Quad configuration (Not Applicable on \*CUWT/\*CMDC/\*CHMDC Series)
- Different table or tank lengths
- Air wipe or blower systems
- Catwalk with guarded rail
- Service step
- Pump service slides with quick-disconnects
- Plate and Frame/Shell and Tube heat exchangers
- Differential pressure and temperature gauges
- Dual or single stainless steel basket filter with bypass system
- Water recirculation, integrated cooling, and loop control heating systems (\*\*)
- Temperature control
- Heavy-duty stainless steel support frame
- Insulation on tanks and/or all water components
- Central greasing system
- Touch screen controls (HMI) (Included on \*CVCE/\*CPVS Series, and Medical Tanks)
- Programmable recipes
- Allen-Bradley, Omron, and Siemens packages available (\*\*)
- Line Integration: Hard-wired interconnection (analog microprocessor interface, speed signal to measuring device, encoder I/O), Ethernet/IP available
- Electrics: 230-460-575VAC/3PH/60 Hz, 380-400VAC/3PH/50 Hz
- UL-CSA-CE Certification

(\*\*): All motors are Energy-Efficient  
 (\*): Other brands available upon request

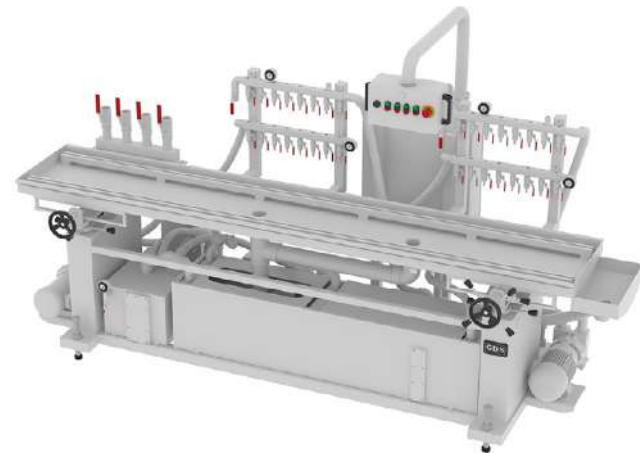
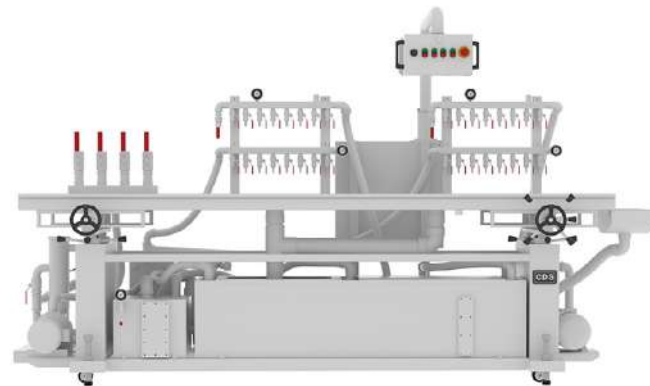

**CALIBRATION TABLE OPTIONS**

- Customizable vacuum and water manifolds
- Vacuum pumps - Dry vacuum (\*\*)
- Cyclone systems - Wet vacuum (\*\*)
- Stainless steel drilled and tapped mounting rails
- Motorized longitudinal table movement: 2-speed forward, 1-speed reverse
- Angularity adjustment (\*CVCE)
- Integrated Haul-Off controls (\*CVC)
- Analog controls (\*CVCE)

(\*\*): All motors are Energy-Efficient  
 (\*CVC): Applicable only on Vacuum Calibration Tables  
 (\*CVCE): Applicable only on Energy-Efficient Vacuum Calibration Tables  
 (\*): Other brands available upon request

\*CVSP: CDS Vacuum Sizing Stand  
**Note:** Vacuum Sizing Stands available upon request

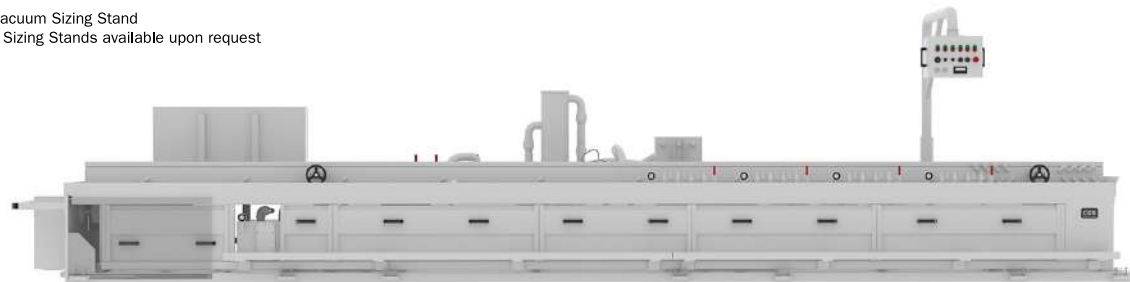
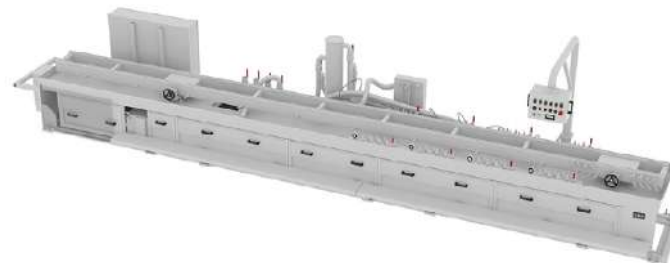

**TANK OPTIONS**

- Customizable vacuum and water manifolds (\*CVS/\*CVSS/\*CVSSD/\*CVSS-R)
- Vacuum pumps - Dry vacuum (\*CVS/\*CVSS/\*CVSSD/\*CVSS-R)
- Ultrasonic wall unit mounting
- Gas springs (locking lids)
- Stainless steel lids
- Hinged safety clear-view lids
- Entrance and/or exit horizontal and vertical adjustable guide rollers
- Motorized take-up unit
- Iris for product range
- Fine micron filter bags
- Heat thermolators
- Vector or Servo control systems (\*\*) (\*CUWT/\*CWTM/\*CMWTM)
- Servo driven first pass sheave to minimize stretching (\*CWTM/\*CMWTM)
- Additional non-driven sheaves for five pass operation (\*CWTM/\*CMWTM)
- Medical grade stainless steel support frame
- UV water purification system
- Water evacuation pumps (\*CVS/\*CVSS/\*CVSSD/\*CVSS-R)
- Contoured support rollers or saddles
- Adjustable product support rollers from outside of tank via hand wheel
- Ovality control roll assembly

(\*\*): All motors are Energy-Efficient  
 (\*CVS): Applicable only on Vacuum Sizing Tanks  
 (\*CVSS): Applicable only on Vacuum Spray Sizing Tanks  
 (\*CVSSD): Applicable only on Dodecagonal Vacuum Spray Sizing Tanks  
 (\*CVSS-R): Applicable only on Round Vacuum Spray Sizing Tanks  
 (\*CWTM): Applicable only on Multi-Pass Water Cooling Tanks  
 (\*CMWTM): Applicable only on Medical Multi-Pass Water Cooling Tanks  
 (\*): Other brands available upon request

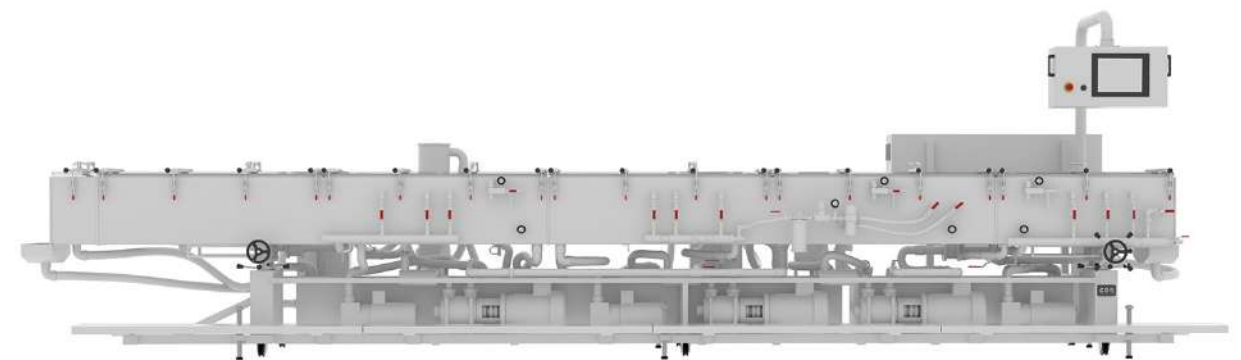

**DRUM COOLER OPTIONS**

- Different drum widths and diameters
- Air wipe or blower systems
- Vector or Servo control systems





## PULLING MACHINES

CDS offers its series of Pulling Machines, designed to provide steady and precise traction for extruded applications of different materials, sizes, and hardness ratings. Safe and easy to operate with minimal maintenance requirements provide a precise pulling solution.

### BELT HAUL-OFFS

CDS' Belt Haul-Offs are designed and manufactured with varying speed ranges, contact lengths, belt configurations, and belt materials for maximum flexibility to target customers' specific extrusion requirements.

- Standard Specifications:**
- DuraGrip covered belts
  - Full coverage safety enclosure
  - Heavy-duty gearboxes and steel construction
  - Chain drive system with vector controls (Series 25 to 60)
  - Line direction: Right-Left/Left-Right
  - 0-10VDC, or 4-20 mA Line Integration

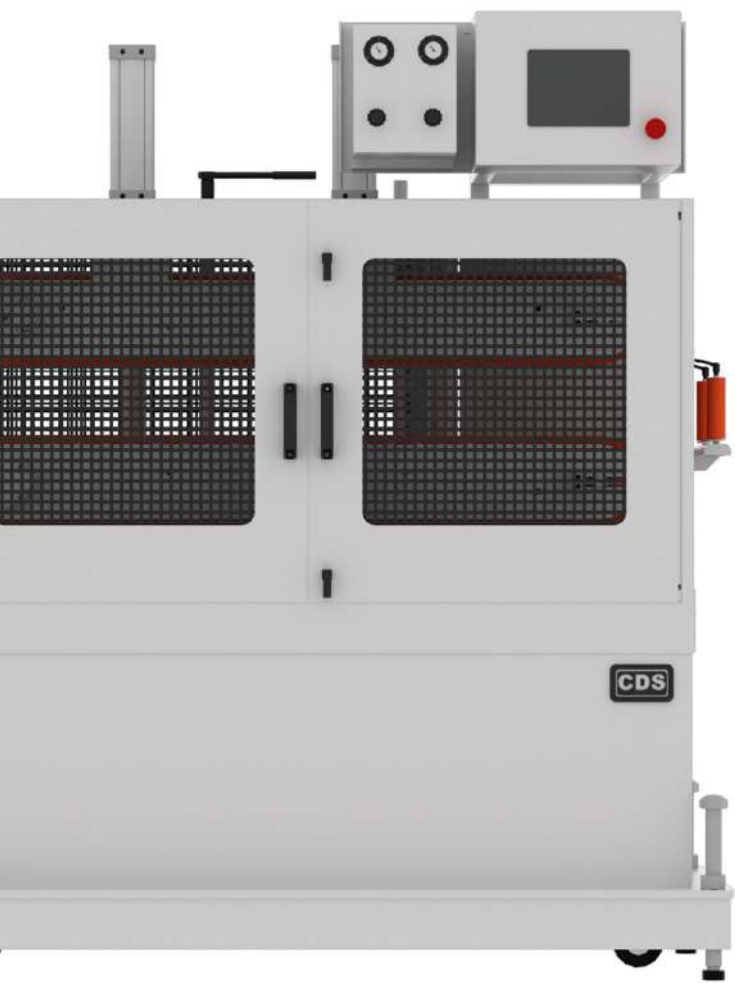

- ✓ Manual self-centering conveyor adjustment (Series 9.5 to 18)
- ✓ Manual conveyor beam height adjustment (Series 25 to 60)
- ✓ Timing belt drive system with servo controls (Series 9.5 to 11)
- ✓ Timing belt drive system with vector controls (Series 16 to 18)

### BELT HAUL-OFFS

#### CBH SERIES

STANDARD FEATURES	CBH95	CBH11	CBH16	CBH18	CBH25	CBH36	CBH40	CBH48	CBH60
Conveyor Length	9.5"	11"	16"	18"	25"	36"	40"	48"	60"
Conveyor Width	2", 3", 4"				4", 6", 8", 10", 12"				
Max. Conveyor Opening	3"				7"				

\*CBH: CDS Belt Haul-Off



✓ Manual self-centering conveyor adjustment

### HORIZONTAL BELT HAUL-OFFS

#### CBH-H SERIES

STANDARD FEATURES	CBH25H	CBH36H	CBH40H	CBH48H
Conveyor Length	25"	36"	40"	48"
Conveyor Width	4", 6", 8"			
Max. Conveyor Opening	7"			

\*CBH-H: CDS Horizontal Belt Haul-Off

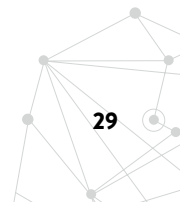
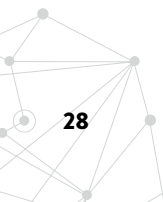



**MEDICAL HAUL-OFFS**

To accommodate the size and the unique processing requirements of extruded medical tubes, CDS offers its Series of Medical Pulling Machines, designed to provide a steady and precise pulling solution.

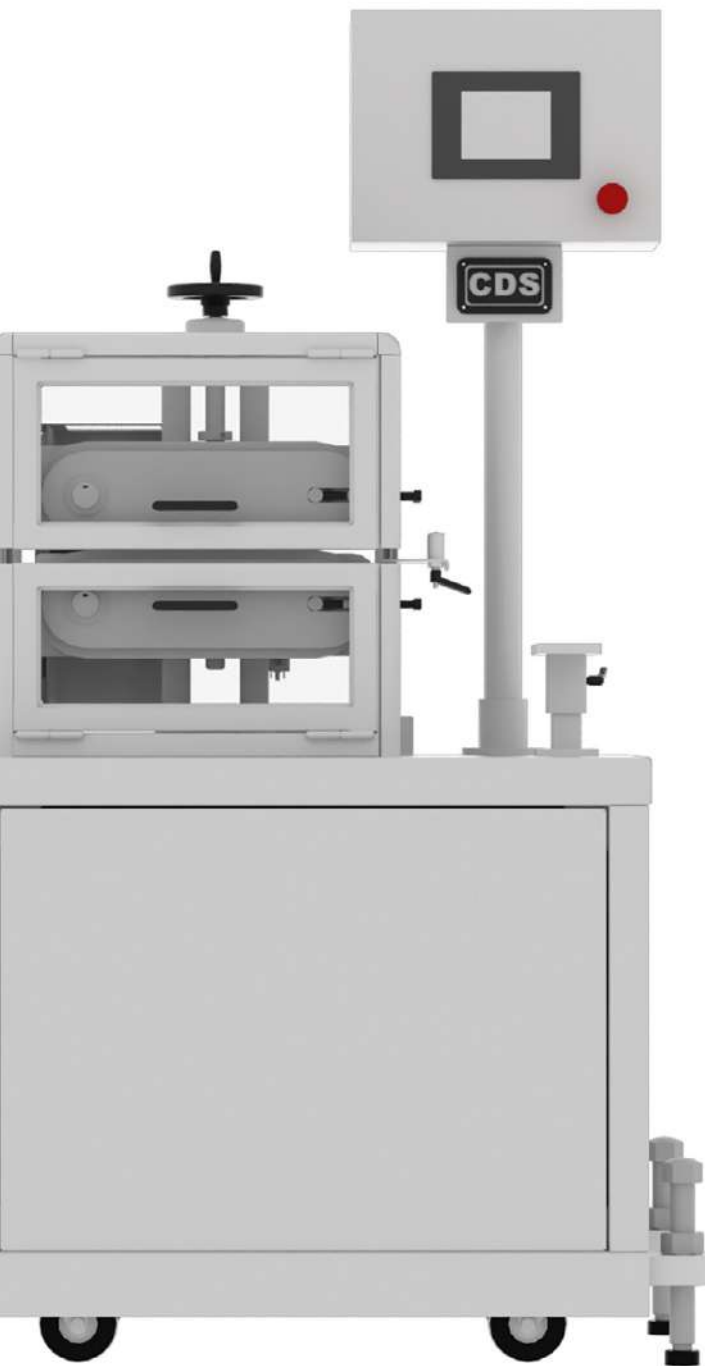

- Standard Specifications:**
- Clean room ready
  - FDA approved non-marking belt or pinch roll material
  - Full coverage safety enclosure
  - Touch screen controls (HMI)
  - Line direction: Right-Left/Left-Right
  - 0-10VDC, or 4-20 mA Line Integration

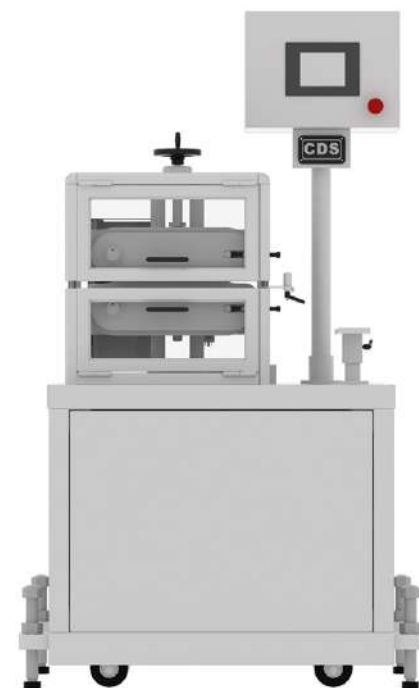

**MEDICAL BELT HAUL-OFFS**

**CMBH SERIES**

STANDARD FEATURES	CMBH95	CMBH12	CMBH18
Conveyor Length	9.5"	12"	18"
Conveyor Width	2", 3", 4"		
Max. Conveyor Opening	3"		

\*CMBH: CDS Medical Belt Haul-Off

- ✓ Horizontal and vertical adjustable guide rollers
- ✓ Manual self-centering conveyor adjustment
- ✓ Timing belt drive system with servo controls



**MEDICAL ROLL HAUL-OFFS**

**CMRH SERIES**

STANDARD FEATURES	CMRH4	CMRH8
Roll O.D.	4"	8"
Roll Width	2", 3", 4"	

\*CMBH: CDS Medical Belt Haul-Off

- ✓ Manual self-centering pinch roller adjustment
- ✓ Servo motor and drive system
- ✓ Driven pinch rollers

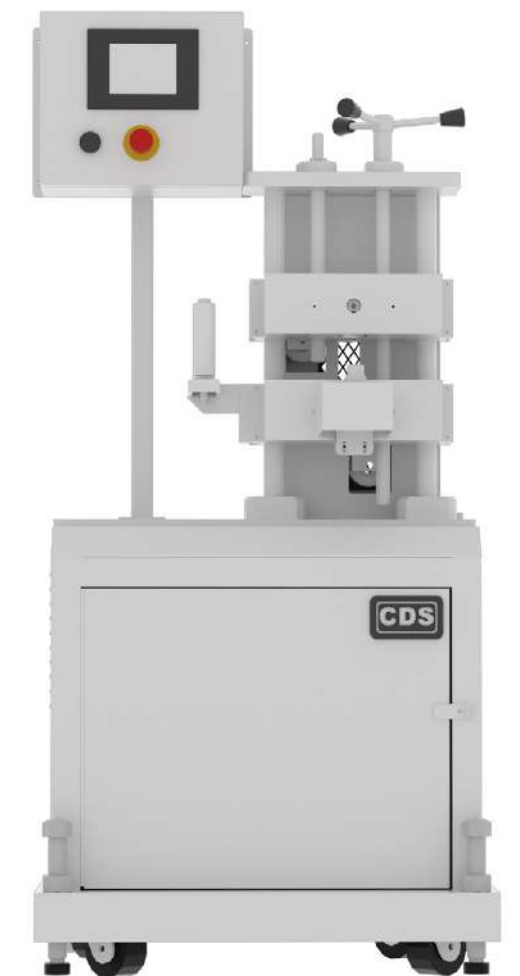

**CLEAT HAUL-OFFS**

CDS' Cleat Haul-Offs have a robust platform designed to eliminate slippage and distortion of the extruded product, and can match the unique contour of the processor's profile.

**Standard Specifications:**

- Full coverage safety enclosure
- Safety doors for easy operator access
- Heavy-duty gearboxes and steel construction
- Vector closed-loop electrical system with encoder feedback
- Manual lower beam height adjustment
- Fixed or quick-change cleats
- Chain drive or direct drive system
- Line direction: Right-Left/Left-Right
- 0-10VDC, or 4-20 mA Line Integration

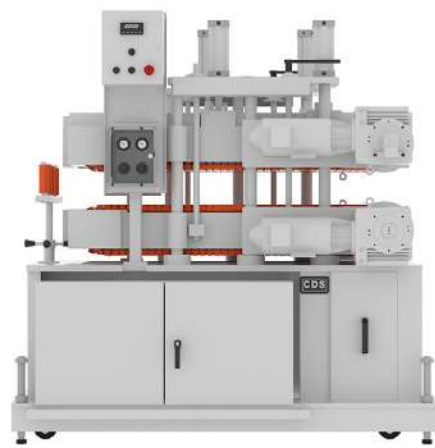
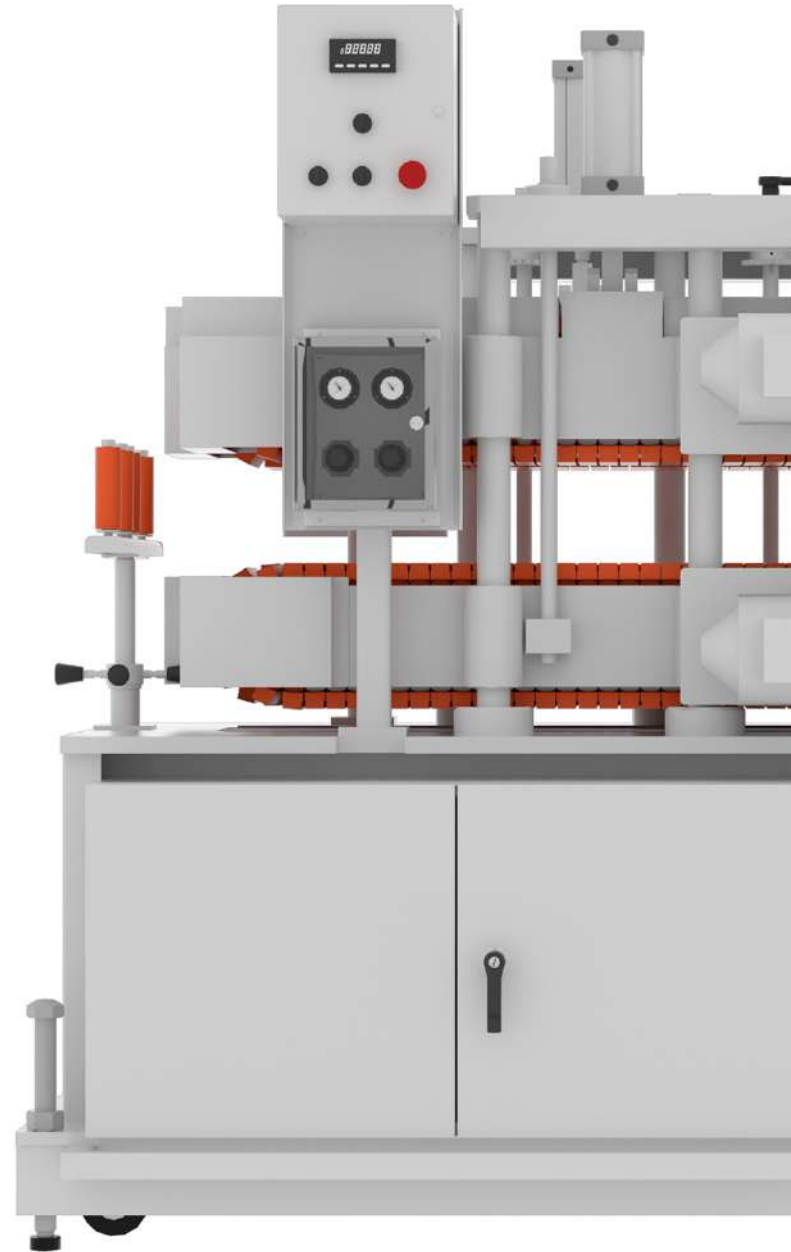

**CCH SERIES**



STANDARD FEATURES	CCH25	CCH36	CCH40	CCH48
Conveyor Length	25"	36"	40"	48"
Conveyor Width (Fixed Cleats - *Type A)	4", 5", 7", 10", 12"			
Conveyor Width (Fixed Cleats - *Type B)	4", 5", 6", 8", 12", 15", 18", 24", 27", 30", 32", 40", 48", 50", 52", 60"			
Conveyor Width (Quick-Change Cleats)	7", 10", 12"			
Cleat Width (V-cleats)	3.5"		3.5"	
Max. Conveyor Opening (Between Cleats)	7"			

\*CCH: CDS Cleat Haul-Off  
 \*Type A: 1 3/4" thickness  
 \*Type B: 1 1/4" thickness  
 Note: CCH 36, 40, and 48 Series available for Pipe or Tube applications with V-cleats

✓ Manual conveyor height adjustment

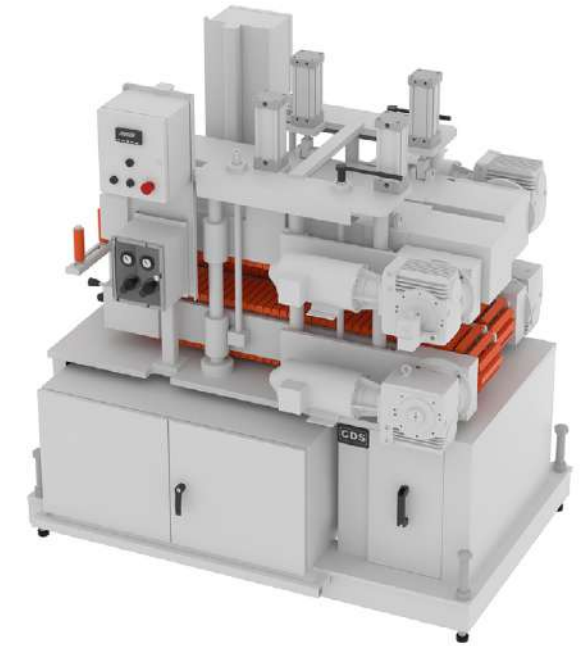

**CCH SERIES**



STANDARD FEATURES	CCH60	CCH70	CCH84	CCH96	CCH120	CCH144
Conveyor Length	60"	72"	84"	96"	120"	144"
Conveyor Width (Fixed Cleats - *Type A)	7", 10", 12", 15", 18", 24", 36", 48", 60"					
Conveyor Width (Fixed Cleats - *Type B)	4", 5", 6", 8", 12", 15", 18", 24", 27", 30", 32", 40", 48", 50", 52", 60"					
Conveyor Width (Quick-Change Cleats)	7", 10", 12", 15", 18", 24"					
Max. Conveyor Opening (Between Cleats)	6"					

\*CCH: CDS Cleat Haul-Off  
 \*Type A: 1 3/4" thickness  
 \*Type B: 1 1/4" thickness

✓ Upper beam with pneumatic clamping control

✓ Remote control



**PIPE HAUL-OFFS**

CDS' Pipe Haul-Offs are designed to provide sturdy, consistent traction to process extruded and co-extruded pipes or tubes of various sizes and materials for processing small, medium, at maximum output rates.



**Standard Specifications:**

- Full coverage safety enclosure
- Safety doors for easy operator access
- Heavy-duty gearboxes and steel construction
- Vector closed-loop electrical system with encoder feedback
- Remote control
- Direct drive system
- Pneumatic beam adjustment (top and sides)
- Lower conveyor beam(s) with manual or motorized adjustment
- Line direction: Right-Left/Left-Right
- 0-10VDC, or 4-20 mA Line Integration

**CPH SERIES**



STANDARD FEATURES	CPH240	CPH260	CPH440	CPH460	CPH660	CPH872	CPH1072	CPH1084	CPH1284	CPH1484
Conveyor Length	40"	60"	40"	60"	60"	72"	72"	84"	84"	84"
Conveyor Width	3.5"	3.5"	3.5"	3.5"	4"	4"	4"	4"	4"	4"
Conveyor Arms	2	2	4	4	6	8	10	10	12	14
O.D. Capacity	½" to 6"	½" to 6"	¼" to 6"	½" to 16"	6" to 24"	18" to 36"	20" to 40"	24" to 48"	30" to 54"	36" to 60"

\*CPH: CDS Pipe Haul-Off



**ROLL HAUL-OFFS**

CDS' Roll Haul-Offs are recognized for their cost-effective, compact designs in non-medical and medical applications.

**Standard Specifications:**

- Full coverage safety enclosure
- Heavy-duty gearboxes and steel construction
- Vector closed-loop electrical system with encoder feedback
- Manual pinch roller height adjustment
- Driven pinch rollers
- Chain drive system
- Line direction: Right-Left/Left-Right



**CRH SERIES**



STANDARD FEATURES	CRH4	CRH8
Roll O.D.	4"	8"
Roll Width	2", 3", 4", 6", 8", 10", 12"	

\*CRH: CDS Roll Haul-Off

**SLAB-TUBE/ROD HAUL-OFF BRAKES**

With immense hold-back/pulling force, sizeable contact area, and a solid platform, CDS' Slab-Tube/Rod Haul-Off Brakes have been designed to pull extruded sheets, rods, or tubes of different materials for a wide range of applications.

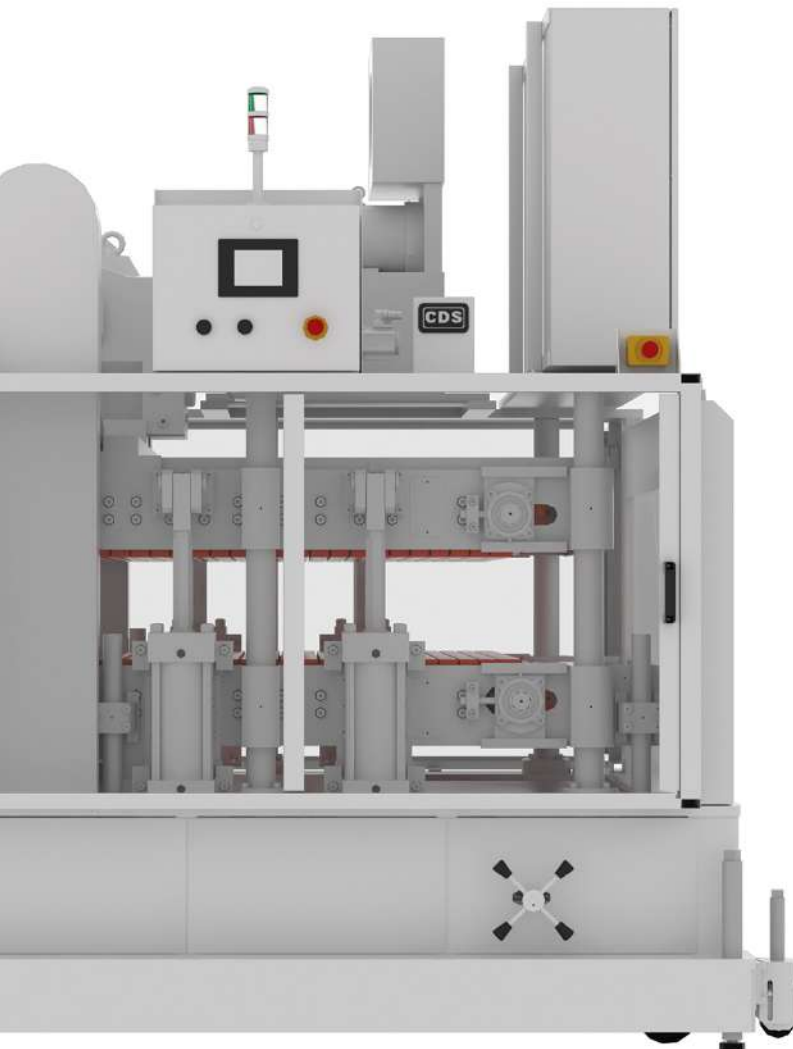

**Standard Specifications:**

- Full coverage safety enclosure
- Heavy-duty gearboxes and steel frame construction
- Vector closed-loop electrical system with encoder feedback
- Upper beam with hydraulic clamping control system
- Lower beam with motorized/manual height adjustment
- Touch screen controls (HMI)
- Line direction: Right-Left/Left-Right

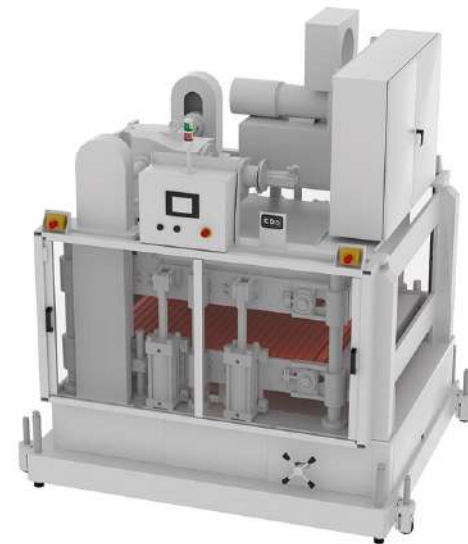

**SLAB/ROD HAUL-OFF BRAKES**

**CCHB-H SERIES**

STANDARD FEATURES	CCHB48H	CCHB60H	CCHB72H
-------------------	---------	---------	---------

Conveyor Length	48"	60"	72"
-----------------	-----	-----	-----

Conveyor Width	Up to 60"		
----------------	-----------	--	--

Max. Conveyor Opening (Between Cleats)	Up to 24"		
--	-----------	--	--

\*CCHB: CDS Slab/Rod Haul-Off Brake

- ✓ Fixed cleats
- ✓ Cleat pads adapted for slab or rod applications

**TUBE/ROD HAUL-OFF BRAKES**

**CCHB-HQ SERIES**

STANDARD FEATURES	CCHB48HQ	CCHB60HQ	CCHB72HQ
-------------------	----------	----------	----------

Conveyor Length	48"	60"	72"
-----------------	-----	-----	-----

Conveyor Width	18"		
----------------	-----	--	--

Max. Conveyor Opening (Between Cleats)	30"		
--	-----	--	--

\*CCHB-HQ: CDS Tube/Rod Haul-Off Brake

**PULLING OPTIONS**

- Dual configuration
- Customizable cleat, belt, or pinch roller configuration
- Different cleat, belt, or pinch roller materials, thicknesses, colours, and durometers available
- Various FDA approved non-marking belt and roll materials available (\*CMBH/\*CMRH)
- High temperature belt, cleat, or roll material
- Servo-motorized clamping control with touch screen controls (HMI)
- Upper beam with pneumatic clamping control (\*CBH/\*CCH Series 25 to 48)
- Pneumatic self-centering conveyor adjustment
- Manual self-centering conveyor adjustment (\*CBH/\*CCH)
- Remote control (wireless remote control available)
- Direct drive system with vector controls and motors (\*\*)  
(\*CBH/\*CCH) (Not applicable on \*CBH Series 9.5 to 18)
- Direct drive system with servo controls, motors, and touch screen (\*\*)
- Horizontal and vertical adjustable guide rollers
- Length or Footage counter
- Digital gap indicator
- Forklift slots on frame
- Conveyor angle adjustment to prevent part distortion (\*CBH)
- Wall thickness control system
- Heavy-duty stainless steel support frame (Not applicable on \*CMBH/\*CMRH Series)
- Medical grade stainless steel support frame (\*CMBH/\*CMRH)
- Central greasing system
- Touch screen controls (HMI)
- Programmable recipes
- Allen-Bradley, Omron, and Siemens packages available (\*)
- Line Integration: Hard-wired interconnection (analog microprocessor interface, speed signal to measuring device, encoder I/O), Ethernet/IP available
- Electrics: 230-460-575VAC/3PH/60 Hz, 380-400VAC/3PH/50 Hz
- UL-CSA-CE Certification

(\*\*): All motors are Energy-Efficient  
 (\*CBH): Applicable only on Belt Haul-Offs  
 (\*CCH): Applicable only on Cleat Haul-Offs  
 (\*CMBH): Applicable only on Medical Belt Haul-Offs  
 (\*CMRH): Applicable only on Roll Haul-Offs  
 (\*): Other brands available upon request

- ✓ Quick-change cleats
- ✓ Cleat pads adapted for tube or rod applications

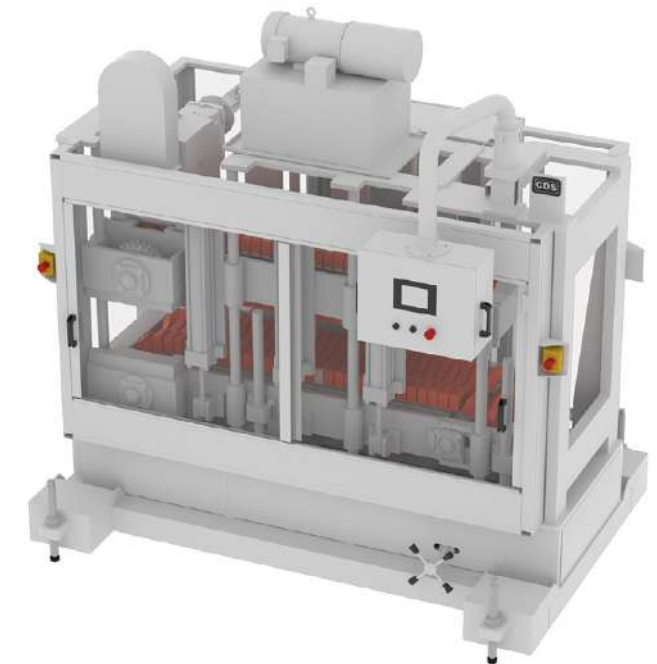
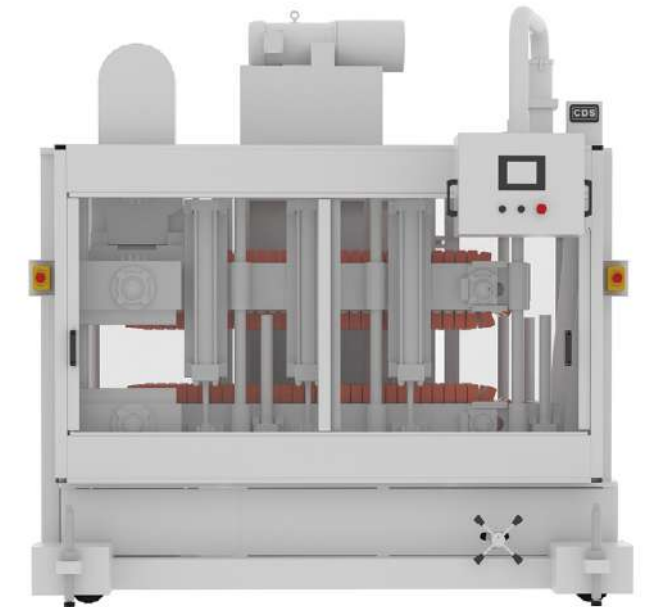

## CUTTING MACHINES

CDS' Cutting Machines are designed and manufactured with a sturdy construction to provide straight, clean cuts for extruded products of different materials and sizes. The unit's blade cuts in synchronization with the extrusion line speed to achieve cut-to-length precision. Our servo models increase line speed, cutting accuracy, and provide consistent cutting.

### PNEUMATIC AND SERVO SAWS

CDS' Series of Pneumatic Saws are ideal for cutting larger, heavy-wall, and rigid extrudates that cannot be effectively cut with fly-knife cutters.

CDS' Servo Saws increase line speed, cutting accuracy, and provide consistent cutting for tighter tolerances and offer ease of operation by eliminating pneumatic table travel adjustments.

Customers may choose from up-cut, down-cut, cross-cut, and multi-pass orientations to meet specific cutting needs.



#### Standard Specifications:

- Heavy-duty steel construction
- Pneumatic or servo table travel
- Fully guarded for maximum machine operator safety
- Cut length accuracy  $\pm .125$  inch (Pneumatic packages)
- Cut length accuracy  $\pm .015$  inch (Servo packages)
- Brake for quick blade stop
- Integrated electronic length control with encoder (Servo packages)
- Pneumatically-assisted carriage travel (Applicable only on Planetary Saws)
- Vacuum Dust/Chip Collector (Servo packages)
- Touch screen controls (HMI) (Servo packages)
- Line direction: Right-Left/Left-Right



### TRAVELING CUT-OFF SAWS

#### CTS/CSS/CSSH SERIES

STANDARD FEATURES	CTS3-3	CTS45-8	CTS65-13	CTS85-18	CTS11-24	CTS13-28
Profile Cutting Window (W x H)	3.5" x 2.5"	8" x 3.5"	13" x 3.5"	18" x 4.5"	22" x 4.5"	28" x 5"
Profile Cutting Window (H x W)	3" x 2.5"	4.5" x 4"	6" x 2.5"	8" x 9"	10" x 4.5"	12.5" x 4.5"
Pipe Cutting Window O.D.	3"	4.5"	6.5"	8.5"	11"	13"
Saw Blade Diameter	10"	14"	18"	24"	28"	33"

\*CTS: CDS Traveling Cut-Off Saw  
 \*CSS: CDS Servo Precision Cut-Off Saw  
 \*CSSH: CDS High Velocity Servo Precision Cut-Off Saw (Up to 85-18 model)

- ✓ Upward blade cutting
- ✓ Servo controls with extended table travel (\*CSSH)



### TRAVELING DOWN-CUT SAWS

#### CTSD/CSSD/CSSDH SERIES

STANDARD FEATURES	CTSD3-3	CTSD45-8	CTSD65-13	CTSD85-18
Cutting Window O.D.	3"	4.5"	6.5"	8.5"
Saw Blade Diameter	10"	14"	18"	24"

\*CTSD: CDS Traveling Down-Cut Saw  
 \*CSSD: CDS Servo Precision Down-Cut Saw  
 \*CSSDH: CDS High Velocity Servo Precision Down-Cut Saw

- ✓ Downward blade cutting
- ✓ Servo controls with extended table travel (\*CSSDH)

**CROSS-CUT SAWS**

**CTSC/CSSC SERIES**

STANDARD FEATURES	CSSC45	CSSC60
Cutting Width	21" up to 62"	
Cutting Window (W x H)	Up to 10"	

\*CTSC: CDS Cross-Cut Saw  
\*CSSC: CDS Servo Precision Cross-Cut Saw

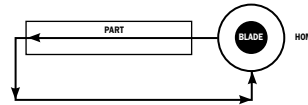

- SAW SEQUENCE:**  
Once-through cross-cut as follows:
- ✓ Saw clamp comes down
  - ✓ Blade travels across part width
  - ✓ Clamp releases (opens)
  - ✓ Saw blade returns home under the table
  - ✓ Table returns to home position



- ✓ Pneumatically activated cross-cut stroke
- ✓ Once-through cross-cut
- ✓ Touch screen controls (HMI)
- ✓ Integrated electronic length control with encoder



**CTSC/CSSC SERIES**

STANDARD FEATURES	CSSC40-15	CSSC40-20
Cutting Width	24" or 28"	40" or 55"
Cutting Window (W x H)	6"	

\*CTSC: CDS Cross-Cut Saw  
\*CSSC: CDS Servo Precision Cross-Cut Saw

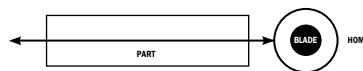

- SAW SEQUENCE:**  
Once-through cross-cut as follows:
- ✓ Saw clamp comes down
  - ✓ Blade travels across part width
  - ✓ Saw blade returns to home position (through the part)
  - ✓ Saw clamp releases part



- ✓ Servo activated cross-cut stroke
- ✓ Programmable cut height in increments

**MULTI-PASS CROSS-CUT SAWS**

**CSSCM SERIES**

STANDARD FEATURES	CTSCM80
Cutting Width	28", 40", 55"
Cutting Height	10"

\*CSSCM: CDS Servo Precision Multi-Pass Cross-Cut Saw

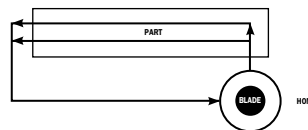

- SAW SEQUENCE:**  
Multi-Pass cross-cut as follows:
- ✓ Blade comes up into the part at first height increment
  - ✓ Blade travels across part width
  - ✓ Blade drops underneath the table and returns home
  - ✓ Cross-cut cycle is repeated multiple times until cut is complete
  - ✓ Blade drops underneath the table
  - ✓ Saw clamp releases part
  - ✓ Blade and table returns home

**CUTTERS**

CDS' Series of Servo Fly-Knife Cutters provide high-speed cutting for custom profiles or tubes of various materials.

Our Rotary Knife-Cutters are equipped with heavy-duty planetary gearboxes and oversized flywheels for a robust cutting solution.

**Standard Specifications:**

- Heavy-duty steel construction
- Fully guarded for maximum machine operator safety
- Cut length accuracy  $\pm .015$  inch
- Lock-down bushings
- Adjustable blade speed
- Blade-holder system driven by heavy-duty servo motor and gearbox\*  
(\*Not applicable on CSFK series)
- Integrated electronic length control with encoder
- Touch screen controls (HMI)
- Line direction: Right-Left/Left-Right



**SERVO FLY-KNIFE CUTTERS**

**CSFK SERIES**

STANDARD FEATURES	CSFK25	CSFK35	CSFK45	CSFK65
Cutting Window O.D.	2.25"	3.25"	4.25"	6.25"
Bushing O.D.	2.5"	3.5"	4.5"	6.5"
X-axis Travel Movement	12"			

\*CSFK: CDS Servo Fly-Knife Cutter



- ✓ Flywheel for added cutting torque

**SERVO ROTARY KNIFE CUTTERS**

**CSRK SERIES**

STANDARD FEATURES	CSRK45	CSRK65
Cutting Window O.D.	4.25"	6.25"
Bushing O.D.	4.5"	6.5"

\*CSRK: CDS Servo Rotary Knife Cutter  
\*Note: Cutting capacity depends on wall thickness

**GUILLOTINES**

CDS' Guillotines offer an excellent alternative to conventional Fly-Knife Cutters and Traveling Saws. They are well-known for their cost effectiveness, reduced noise, and clean cuts.

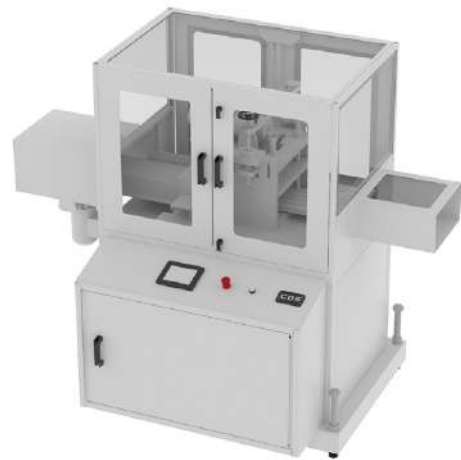
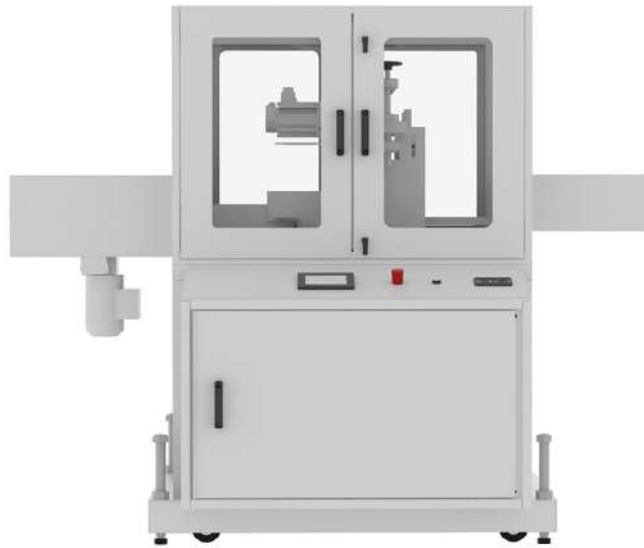

**Standard Specifications:**

- Full coverage safety enclosure
- Pneumatically activated guillotine cutter head
- Pneumatic or servo table travel on precision-aligned rails
- Cut length accuracy ± .125 inch (Pneumatic packages)
- Cut length accuracy ± .015 inch (Servo packages)
- Heavy-duty steel construction
- Fully guarded for maximum machine operator safety
- Touch screen controls (HMI)
- Integrated electronic length control with encoder
- Line direction: Right-Left/Left-Right

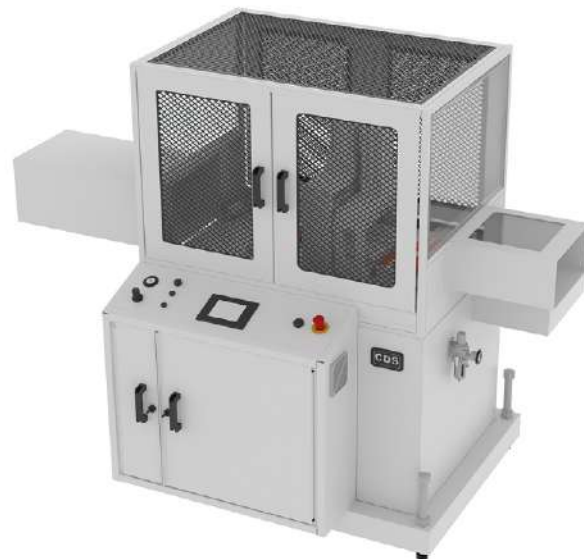

- ✓ Touch screen controls (HMI) (\*CGCPS)
- ✓ Integrated electronic length control with encoder (\*CGCPS)

**TRAVELING GUILLOTINE CUTTERS**

**CGCP/CGCPS SERIES**

STANDARD FEATURES	CGCP8	CGCP13
Cutting Window (Widest)	8"	13"
Cutting Window (Highest)	3"	6"

\*CGCP: CDS Pneumatic Guillotine Cutter/Punch  
 \*CGCPS: CDS Servo Guillotine Cutter/Punch

**TRAVELING PLANETARY SAWS AND SWARFLESS CUTTERS**

CDS' Traveling Planetary Saws and Swarfless Cutters are manufactured to effectively cut pipes of various materials and diameters.

**Standard Specifications:**

- Full coverage safety enclosure
- Pneumatically-assisted carriage travel
- V-shaped clamps
- Heavy-duty steel construction
- Fully guarded for maximum machine operator safety
- Saw blade system driven by AC motor (Applicable only on \*CTPS Series)
- Free-driven toothless blades (Applicable only on \*CTPSC Series)
- Blade rotation system driven by heavy-duty motor and gearbox
- Touch screen controls (HMI)
- Programmable recipes
- Integrated electronic length control with encoder
- Line direction: Right-Left/Left-Right

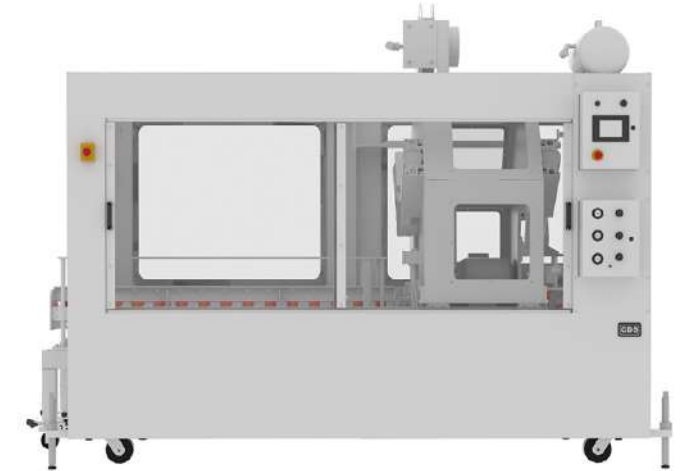

**TRAVELING PLANETARY SAWS AND SWARFLESS CUTTERS**

**CTPSC/CTPS SERIES**

STANDARD FEATURES	CTPSC3-12	CTPSC3-16	CTPSC6-18	CTPSC8-24	CTPSC10-36	CTPSC24-48
O.D. Capacity	3" to 12"	3" to 16"	6" to 18"	8" to 24"	10" to 36"	24" to 48"

\*CTPSC: CDS Traveling Planetary Swarfless Cutter  
 \*CTPS: CDS Traveling Planetary Saw

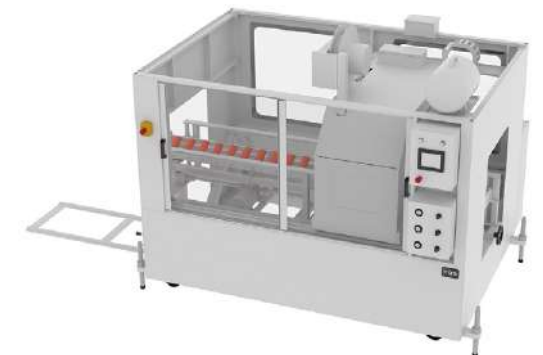
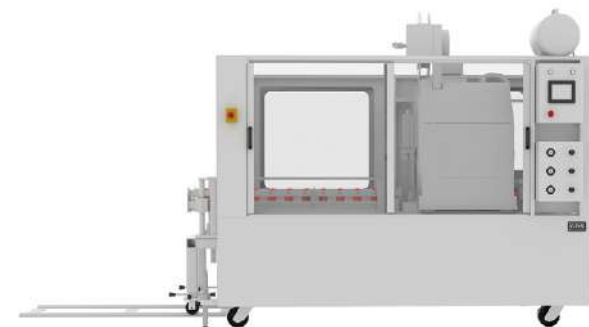

**CHIPLESS HOT BLADES/KNIVES**

CDS offers its new generation of Chipless Cutting Machines. Our CUTPRO Series are designed with a heated blade, which provide chipless and no-waste cutting resulting in higher efficiency by diminishing product loss and overall cost.



**Standard Specifications:**

- Chipless, no-waste hot blade cutting
- Blade heating system
- Heavy-duty steel construction
- Fully guarded for maximum machine operator safety
- Hinged door for easy operator access
- Pneumatic or servo table travel
- Cut length accuracy ± .125 inch (Pneumatic packages)
- Cut length accuracy ± .015 inch (Servo packages)
- Blade knife system powered by motor and gearbox
- Touch screen controls (HMI)
- Integrated electronic length control with encoder
- Line direction: Right-Left/Left-Right

**TRAVELING CHIPLESS HOT BLADES**

**CUTPRO/CUTPRO-S SERIES**

STANDARD FEATURES	CUTPRO300	CUTPRO300S	CUTPRO600	CUTPRO600S
Cutting Window (W x H)	9" x 4.75"	9" x 4.75"	20" x 6.5"	20" x 6.5"
Cutting Window (H x W)	5.5" x 6.5"	5.5" x 6.5"	10" x 10"	10" x 10"
Cut length accuracy	± .120	± .015"	± .120	± .015"
Table travel	18"	26"	20"	26"

\*CUTPRO: CDS Traveling Chipless Hot Blade  
 \*CUTPRO-S: CDS Servo Precision Chipless Hot Blade



**CUTTING OPTIONS**

- Dual configuration
- Selector switch for Automatic/Manual mode
- Cut-length activating sensor
- Central greasing system
- Forklift slots on frame
- Programmable recipes (Not applicable on \*CGCP Series)
- Allen Bradley, Omron, and Siemens packages available (\*)
- Line Integration: Hard-wired interconnection (analog microprocessor interface, speed signal to measuring device, encoder I/O, Ethernet/IP available)
- Electrics: 230-460-575VAC/3PH/60 Hz, 380-400VAC/3PH/50 Hz
- UL-CSA-CE Certification

(\*\*) All motors are Energy-Efficient  
 (\*): Other brands available upon request

**CUTTER OPTIONS**

- Blade heating system (\*CSFK/\*CSRK)
- Heated entrance tunnel (\*CSFK/\*CSRK)
- Additional set of cutter bushings (\*CSFK/\*CSRK)
- Quick-change cutter bushings (\*CSFK/\*CSRK)
- Stainless steel cutter bushings and cutter head (\*CSFK/\*CSRK)
- High-torque planetary gearbox (\*CSFK)
- Stop/Cut/Go mode (Capable of 2-3 cuts per second) (Not applicable on \*CUTPRO/\*CUTPRO-S Series)
- Blade lubrication system with mist or bottle and blade wipe (\*CSFK/\*CSRK)
- 12" X-axis travel movement (\*CSRK)
- Servo ball screw table travel (\*CGCPS/\*CTPSC/\*CUTPRO-S)
- Extended table travel for high speed (\*CGCPS)
- Different cutting windows (\*CGCPS)
- Electronic length control (\*CGCP)
- Dual pre-set electronic length control (\*CGCP)
- Touch screen controls (HMI) (\*CGCP)

(\*CGCP): Applicable only on Pneumatic Guillotine Cutter/Punch  
 (\*CGCPS): Applicable only on Servo Guillotine Cutter/Punch  
 (\*CTPSC): Applicable only on Traveling Planetary Swarfless Cutters  
 (\*CUTPRO): Applicable only on Traveling Chipless Hot Blades  
 (\*CUTPRO-S): Applicable only on Servo Precision Chipless Hot Blades  
 (\*CSFK): Applicable only on Servo Fly-Knife Cutters  
 (\*CSRK): Applicable only on Servo Rotary Knife Cutters

**SAW OPTIONS**

- Full coverage safety enclosure
- Soundproofing
- Vacuum Dust/Chip Collector (\*\*) (Not applicable on CTPSC Series)
- Variable saw blade speed
- Servo controlled vertical blade movement
- Angular cuts available
- Product support jig
- Servo ball screw table travel
- Electronic length control (\*CTS/\*CTSD/\*CTSC)
- Dual pre-set electronic length control
- Batch counter
- Blade lubrication device
- Motorized exit conveyors (\*CTPS/\*CTPSC)
- Chamfering kits (\*CTPS)
- Touch screen controls (HMI) (\*CTS/\*CTSD/\*CTSC)

(\*CTS): Applicable only on Traveling Cut-Off Saws  
 (\*CTSD): Applicable only on Traveling Down-Cut Saws  
 (\*CTSC): Applicable only on Cross-Cut Saws  
 (\*CTPS): Applicable only on Traveling Planetary Saws  
 (\*CTPSC): Applicable only on Traveling Planetary Swarfless Cutters



## COMBINATION UNITS

CDS' Combination Units are recognized for their compact designs and reduced footprint while combining high pull forces with precise cutting capabilities. CDS can customize a combination system for any application.

### BELT HAUL-OFF/CUTTERS-SAWS

CDS' Combination Belt Haul-Off/Servo Cutters can be customized with a variety of belt sizes, materials, and hardness ratings to provide optimal traction along with different bushing diameters for high speed cutting.



#### Standard Specifications:

- Heavy-duty steel common base construction
- Fully enclosed for operator safety
- Vector closed-loop electrical system with encoder feedback
- Upper and lower beam height adjustment
- Both belts driven
- Inline reducer(s)
- Cut length accuracy  $\pm .015$  inch
- Touch screen controls (HMI)
- Integrated electronic length control with encoder
- 12" X-axis travel movement
- Line direction: Right to Left/Left to Right
- 0-10VDC, or 4-20 mA Line Integration



### BELT HAUL-OFF/SERVO FLY-KNIFE CUTTER

#### CCBVSX/CCBSSX SERIES



STANDARD FEATURES	CCBVSX4-25	CCBVSX4-35	CCBVSX4-45	CCBVSX6-35	CCBVSX6-45
Conveyor Length			25", 36", 40"		
Conveyor Width	4"	4"	4"	6"	6"
O.D. Cutting Capacity	2.25"	3.25"	4.25"	3.25"	4.25"

\*CCBVSX: CDS Combination Vector Belt Haul-Off/Servo Fly-Knife Cutter  
 \*CCBSSX: CDS Combination Servo Belt Haul-Off/Servo Fly-Knife Cutter

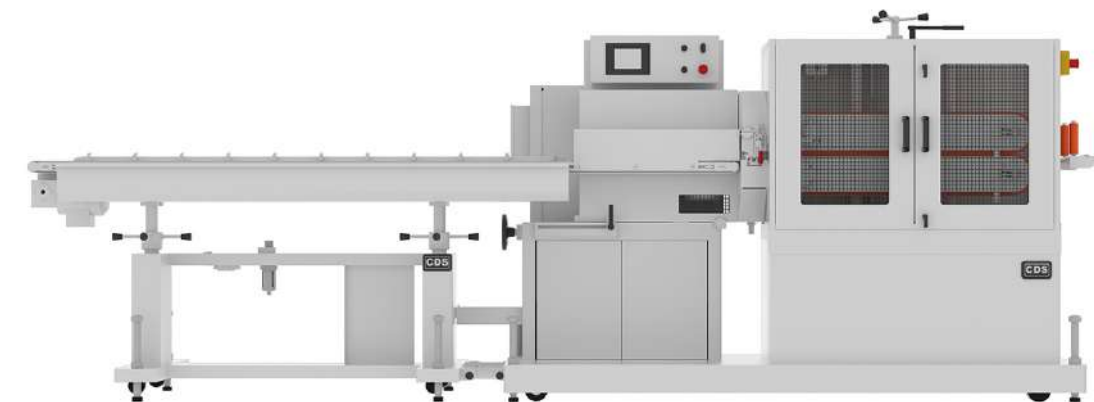

### BELT HAUL-OFF/SERVO ROTARY KNIFE CUTTER

#### CCBVSXK/CCBSSXK SERIES



STANDARD FEATURES	CCBVSXK4-25	CCBVSXK4-65	CCBVSXK6-45	CCBVSXK6-65	CCBVSXK6-85	CCBVSXK8-65	CCBVSXK8-85
Conveyor Length	25"	36"	25", 36"	25", 36", 40", 48"		40", 48"	
Conveyor Width	4"	4"	6"	6"	6"	8"	8"
Cutting Capacity O.D.	4.25"	6.25"	4.25"	6.25"	8.25"	6.25"	8.25"

\*CCBVSXK: CDS Combination Vector Belt Haul-Off/Servo Rotary Knife Cutter  
 \*CCBSSXK: CDS Combination Servo Belt Haul-Off/Servo Rotary Knife Cutter

✓ Flywheel for added cutting torque



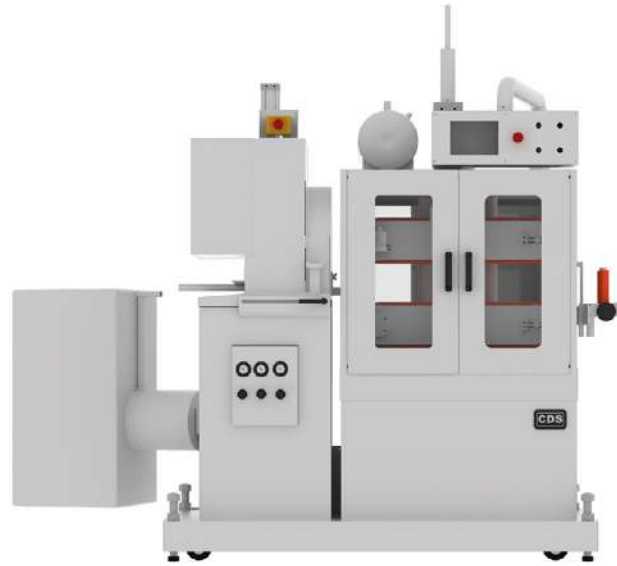

- ✓ Downward blade cutting
- ✓ Blade driven by AC motor

**BELT HAUL-OFF/CHOP SAW**

**CCBVCS/CCBSCS SERIES**

STANDARD FEATURES	CCBVCS25-10	CCBVCS36-14
Conveyor Length	25"	36"
Cutting Capacity O.D.	3"	4.5"

\*CCBVCS: CDS Combination Vector Belt Haul-Off/Chop Saw  
 \*CCBSCS: CDS Combination Servo Belt Haul-Off/Chop Saw  
 Note: Combination Units with integrated conveyor system available upon request

**CLEAT HAUL-OFF/SAWS-CHIPLESS**

CDS' Cleat Haul-Off Combination Units can be combined with our Cut-Off Saws, Chipless Hot Blade Units, or a combination of both. They are highly customizable with fixed or quick-change cleats of various dimensions, materials, and thicknesses while incorporating a pneumatic or servo traveling table of your choice.

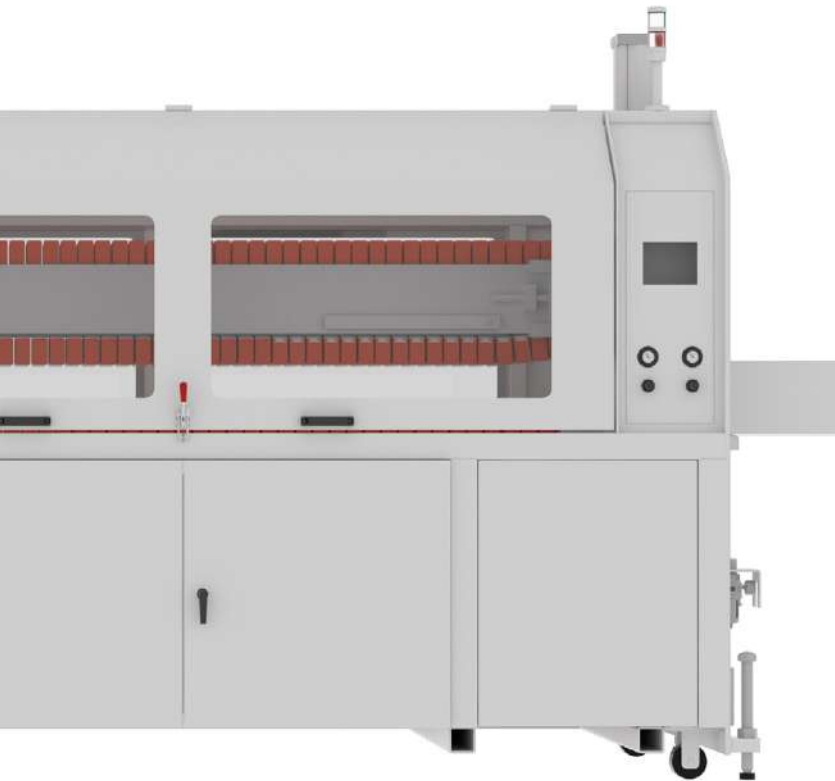

**Standard Specifications:**

- Heavy-duty steel common base construction
- Fully enclosed for operator safety
- Hinged doors for easy operator access
- Direct drive system
- Inline reducers
- Fixed lower conveyor
- Cut length accuracy  $\pm .125$  inch (Pneumatic packages)
- Cut length accuracy  $\pm .015$  inch (Servo packages)
- Touch screen controls (HMI)
- Integrated electronic length control with encoder
- Line direction: Right to Left/Left to Right
- 0-10VDC, or 4-20 mA Line Integration

**CLEAT HAUL-OFF/TRAVELING CUT-OFF SAW**

- ✓ Brake for quick blade stop
- ✓ Automatic clamp adjustment

**CCHS/CCHS-S SERIES**

STANDARD FEATURES	CCHS 60-45	CCHS 60-65	CCHS 72-45	CCHS 72-65	CCHS 96-65	CCHS 96-85	CCHS 120-65	CCHS 120-85	CCHS 144-65	CCHS 144-85
Conveyor Length	60"	60"	72"	72"	96"	96"	120"	120"	144"	144"
Conveyor Width (Fixed Cleats)	7", 10", 12", 15", 18", 24", 36", 48", 60"									
Conveyor Width (Quick-Change Cleats)	7", 10", 12", 15", 18", 24"									
Profile Cutting Window (W x H)	8" x 3.5"	13" x 3.5"	8" x 3.5"	13" x 3.5"	13" x 3.5"	18" x 4.5"	13" x 3.5"	18" x 4.5"	13" x 3.5"	18" x 4.5"
Profile Cutting Window (H x W)	4.5" x 4"	6" x 2.5"	4.5" x 4"	6" x 2.5"	6" x 2.5"	18" x 4.5"	6" x 2.5"	18" x 4.5"	6" x 2.5"	18" x 4.5"

\*CCHS: CDS Combination Cleat Haul-Off/Traveling Cut-Off Saw  
 \*CCHS-S: CDS Combination Cleat Haul-Off/Servo Precision Cut-Off Saw

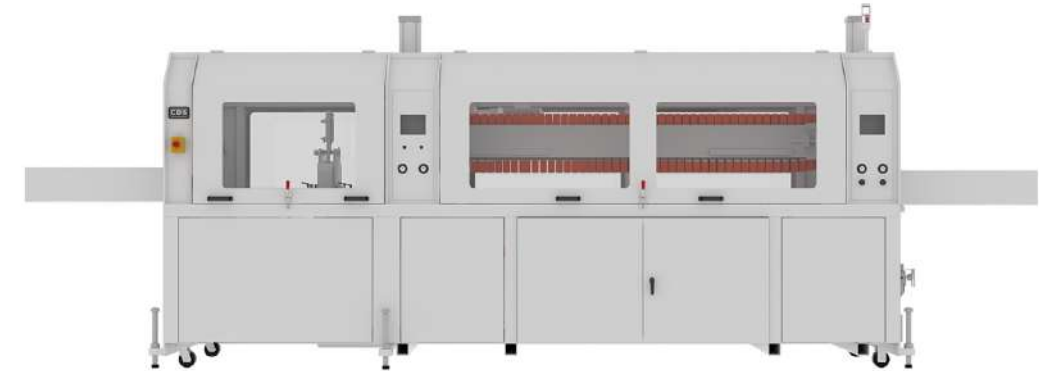

**CLEAT HAUL-OFF/TRAVELING CHIPLESS HOT BLADE**

- ✓ Chipless, no-waste hot blade cutting
- ✓ Blade heating system
- ✓ Blade knife system powered by motor and gearbox

**CCHC/CCHC-S SERIES**

STANDARD FEATURES	CCHC 60-300	CCHC 72-300	CCHC 96-300	CCHC 96-600	CCHC 120-300	CCHC 120-600	CCHC 144-300	CCHC 144-600
Conveyor Length	60"	72"	96"	96"	120"	120"	144"	144"
Conveyor Width (Fixed Cleats)	7", 10", 12", 15", 18", 24", 36", 48", 60"							
Conveyor Width (Quick-Change Cleats)	7", 10", 12", 15", 18", 24"							
Profile Cutting Window (W x H)	9" x 4.75"	9" x 4.75"	9" x 4.75"	20" x 6.5"	9" x 4.75"	20" x 6.5"	9" x 4.75"	20" x 6.5"
Profile Cutting Window (H x W)	5.5" x 6.5"	5.5" x 6.5"	5.5" x 6.5"	10" x 10"	5.5" x 6.5"	10" x 10"	5.5" x 6.5"	10" x 10"

\*CCHC: CDS Combination Cleat Haul-Off/Traveling Chipless Hot Blade  
 \*CCHC-S: CDS Combination Cleat Haul-Off/Servo Precision Chipless Hot Blade

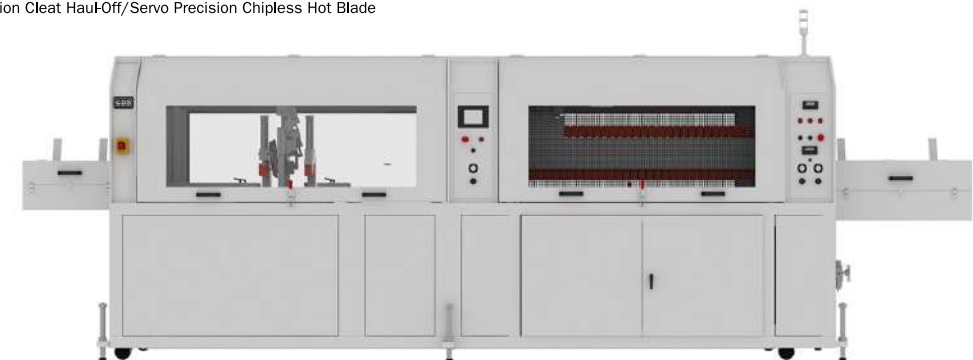

**CLEAT HAUL-OFF/SERVO PRECISION CUT-OFF SAW  
/SERVO PRECISION CHIPLESS HOT BLADE**

**CCHSCP/CCHCP-S SERIES**



STANDARD FEATURES	CCHC72-65-300S	CCHC96-65-300S
Conveyor Length	72"	96"
Conveyor Width (Fixed Cleats)	10"	
Conveyor Width (Quick-Change Cleats)	10"	
Profile Cutting Window (W x H)	13" x 3.55"	
Profile Cutting Window (H x W)	6" x 2.5"	
Chipless Profile Cutting Window (W x H)	9" x 4.75"	
Chipless Profile Cutting Window (H x W)	5.5" x 6.5"	

\*CCHC-300S: CDS Combination Cleat Haul-Off/Servo Precision Cut-Off Saw /Servo Precision Chipless Hot Blade

- ✓ Chipless, no-waste hot blade cutting
- ✓ Blade heating system
- ✓ Blade knife system powered by motor and gearbox
- ✓ Brake for quick blade stop



**MEDICAL COMBINATION UNITS**

CDS' Medical Combination Units, fabricated of medical grade stainless steel components, are recognized for their steady pulling and precise cutting capabilities.

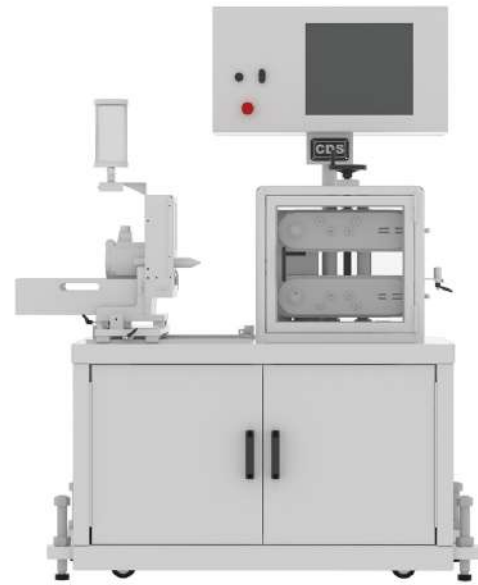

**CMCBSSK SERIES**



STANDARD FEATURES	CMCBSSK95	CMCBSSK12	CMCBSSK18
Conveyor Length	9.5"	12"	18"
Conveyor Width	2", 3", 4"		
Max. Conveyor Opening	3"		
Cutting Capacity O.D.	Micro up to 2.5"		

\*CMCBSSK: CDS Medical Combination Belt Haul-Off/Servo Fly-Knife Cutter  
Note: Combination Roll Haul-Off/Servo Fly-Knife Cutter available upon request

**Standard Specifications:**

- Common base construction
- Fully enclosed for operator safety
- Clean room ready
- Medical grade stainless steel covers and table top, cutter blade, and bushings
- Manual self-centering conveyor adjustment
- FDA approved non-marking belt material
- Both belts driven
- Timing belt drive system
- Inline reducer(s)
- Cut length accuracy ± .015 inch
- Touch screen controls (HMI)
- Integrated electronic length control with encoder
- 2-axis stainless steel cutter head movement on precision rails with locking device
- Line direction: Right to Left/Left to Right
- 0-10VDC, or 4-20 mA Line Integration

**COMBINATION UNIT OPTIONS**

- Dual configuration
- Customizable cleat and belt configuration
- Different cleat and belt materials, thicknesses, colours, and durometers available
- Direct drive system with vector controls and motors (\*\*)  
(Not applicable on Medical Combination Series)
- Direct drive system with servo controls and motors (\*\*)
- Digital gap indicator
- Central greasing system
- Programmable recipes
- Allen Bradley, Omron, and Siemens packages available (\*)
- Line Integration: Hard-wired interconnection (analog microprocessor interface, speed signal to measuring device, encoder I/O), Ethernet/IP available
- Electrics: 230-460-575VAC/3PH/60 Hz, 380-400VAC/3PH/50 Hz
- UL-CSA-CE Certification

(\*\*): All motors are Energy-Efficient  
(\*): Other brands available upon request

**BELT HAUL-OFF/CUTTERS-SAWS OPTIONS**

- Horizontal belt configuration
- Servo-motorized clamping control (Not applicable on Horizontal Combination Series)
- Upper beam with pneumatic clamping control (Not applicable on Horizontal Combination Series)
- Pneumatic self-centering beam adjustment
- Remote control (wireless remote control available)
- Timing belt drive system (Not applicable on CCBVCS)
- Blade heating system (Not applicable on CCBVCS)
- Additional set of cutter bushings (Not applicable on CCBVCS)
- Quick-change cutter bushings (Not applicable on CCBVCS)
- Stainless steel cutter bushings and cutter head (Not applicable on CCBVCS)
- Dual blade holder (Not applicable on CCBVCS)
- High-torque planetary gearbox (\*CCBVS/\*CCBSSK) (Not applicable on CCBVCS)
- Cut-length activating sensor
- Stop/Cut/Go mode (Capable of 2-3 cuts per second)
- Forklift slots on frame
- Blade lubrication system with mist or bottle and blade wipe
- Vacuum Dust/Chip Collector (\*\*)(\*CCBVS)
- Adjustable blade speed (\*CCBVS)
- Blade lubrication device (\*CCBVS)

(\*CCBVS): Applicable only on Combination Belt Haul-off/Chop Saws  
Horizontal Combination Series: CCBVSK-H, CCBSSK-H, CCBSSRK-H, and CCBVSRK-H

**CLEAT HAUL-OFF/SAWS-CHIPLESS OPTIONS**

- Lower beam height adjustment
- Length or Footage counter
- Vacuum Dust/Chip Collector (\*\*)(Not applicable on \*CCHC/\*CCHC-S series)
- Variable saw blade speed
- Servo ball screw table travel (Not applicable on \*CCHS/\*CCHC series)
- Servo controlled vertical blade movement (Not applicable on \*CCHC/\*CCHC-S series)
- Angular cuts available (Not applicable on \*CCHC/\*CCHC-S series)
- Product support jig (Not applicable on \*CCHC/\*CCHC-S series)
- Batch counter (Not applicable on \*CCHC/\*CCHC-S series)
- Cut-length activating sensor (Not applicable on \*CCHC/\*CCHC-S series)
- Blade lubrication system with mist or bottle and blade wipe

(\*CCHS): CDS Combination Cleat Haul-Off/Traveling Cut-Off Saws  
(\*CCHS-S): CDS Combination Cleat Haul-Off/Servo Precision Cut-Off Saws  
(\*CCHC): CDS Combination Cleat Haul-Off/Traveling Chipless Hot Blades  
(\*CCHC-S): CDS Combination Cleat Haul-Off/Servo Precision Chipless Hot Blades

**MEDICAL COMBINATION UNIT OPTIONS**

- Customizable belt configuration
- Various FDA approved non-marking belt materials available
- Servo-motorized clamping control
- Blade heating system
- Additional set of cutter bushings
- Quick-change cutter bushings
- Cut-length activating sensor
- Bump/Taper tubing package
- Stop/Cut/Go mode (Capable of 2-3 cuts per second)
- Medical grade stainless steel support frame
- Blade lubrication system with mist



## COLLECTION MACHINES

CDS offers pneumatically-activated tables, motorized conveyors, winders, and coilers that safely collect a wide range of plastic extruded products. Our rugged and reliable Collection Machines can quickly load material into a bundling rack, bin, or coil for secondary handling.

### COLLECTION TABLES

CDS' Collection Tables are pneumatically controlled via an electronic timer, a mechanical limit switch, or a photo-optic sensor, and can be customized with different table widths and bin types. They provide a sturdy holding area for final cut parts for easy pick-up at the end of the extrusion line.

#### TILT TABLES

- Heavy-duty steel construction
- Transfer material quickly to a collection area
- Tilt-action control
- Line direction: Right to Left/Left to Right

CTT SERIES				
STANDARD FEATURES	CTT6	CTT8	CTT12	CTT15
Table Length	Up to 24'			
Table Width	6"	8"	12"	15"

\*CTT: CDS Tilt Table

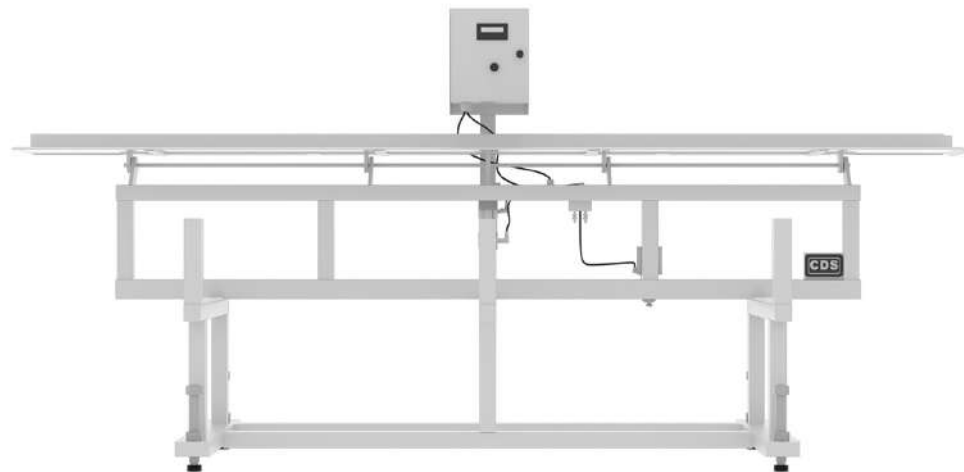

CTTP SERIES			
STANDARD FEATURES	CTTP6	CTTP8	CTTP12
Table Length	Up to 24'		
Pipe Capacity O.D.	Up to 6"	Up to 8"	Up to 12"

\*CTTP: CDS Pipe Tilt Table

✓ V-shaped table



#### RUN-OFF TABLES

- Heavy-duty steel construction
- Run-out rack with rollers
- Customizable roller orientation and collection area
- Sorting area
- Line direction: Right to Left/Left to Right

CRT SERIES		
STANDARD FEATURES	CRT32	CRT58
Table Length	Up to 24'	
Roller Width	32"	58"

\*CRT: CDS Run-Off Table

✓ Fixed table



✓ V-shaped table

CRTP SERIES				
STANDARD FEATURES	CRTP12	CRTP24	CRTP48	CRTP60
Table Length	Up to 24'			
Pipe Capacity O.D.	Up to 12"	Up to 24"	Up to 48"	Up to 60"

\*CRTP: CDS Pipe Run-off Table

#### STACKING TABLES

- Heavy-duty steel construction
- Table height adjustable to product thickness
- Hydraulic or servo actuation system
- Touch screen controls (HMI)
- Programmable recipes
- Line direction: Right to Left/Left to Right

\*CSM: CDS Stacking Machine

Note: Different sizes available upon request

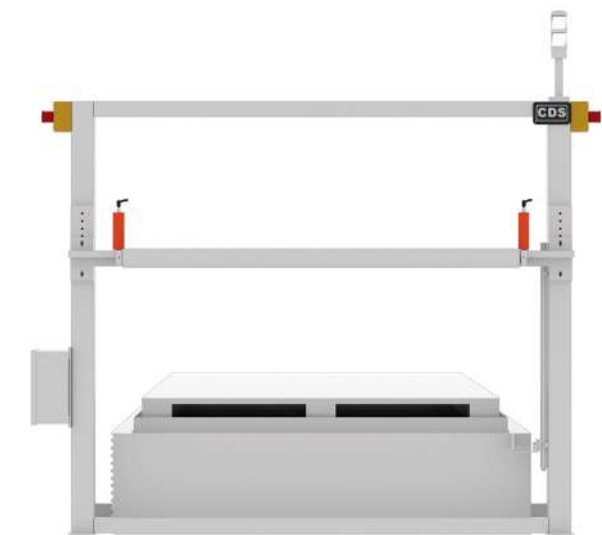

TAKEAWAY CONVEYORS

CDS' Motorized Takeaway Conveyors quickly transfer light profiles or tubes at the end of the extrusion line into a catch bin via a pneumatic discharge system or mechanical pusher arm. They can be customized with different conveyor widths, lengths, speeds, and collection bin types.

Standard Specifications:

- Heavy-duty steel construction (Applicable only on \*CTC Series)
- Motorized conveyor
- Single axis height adjustment
- Pneumatic ejector system
- Line direction: Right-Left/Left-Right

CTC SERIES

STANDARD FEATURES	CTC3	CTC4	CTC6	CTC8
Conveyor Width	3"	4"	6"	8"
Conveyor Length	Up to 20'			

\*CTC: CDS Takeaway Conveyor

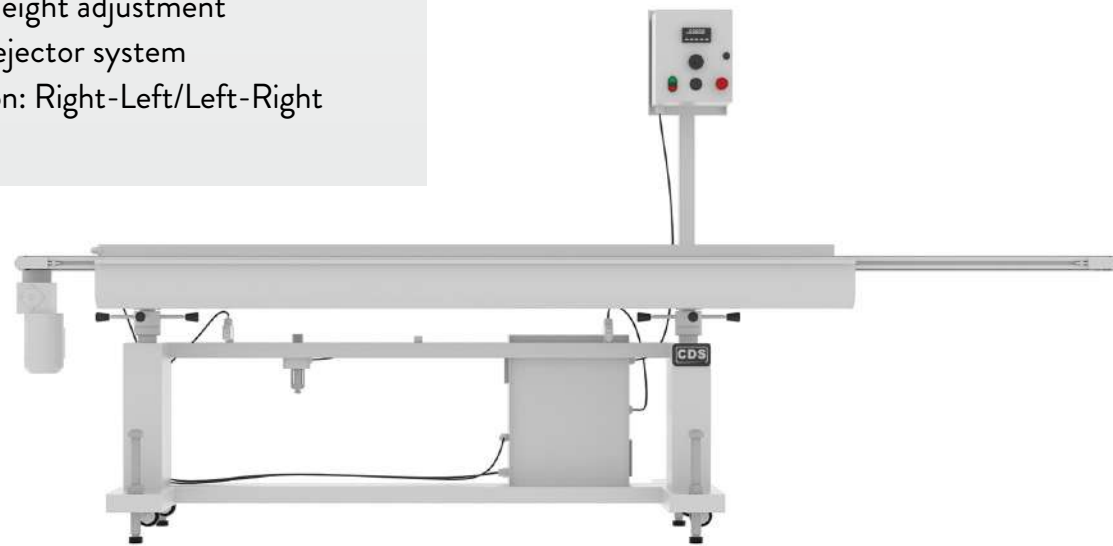

CMTC SERIES

STANDARD FEATURES	CMTC2	CMTC4
Conveyor Width	Up to 4"	
Conveyor Length	14'	

\*CMTC: CDS Medical Takeaway Conveyor

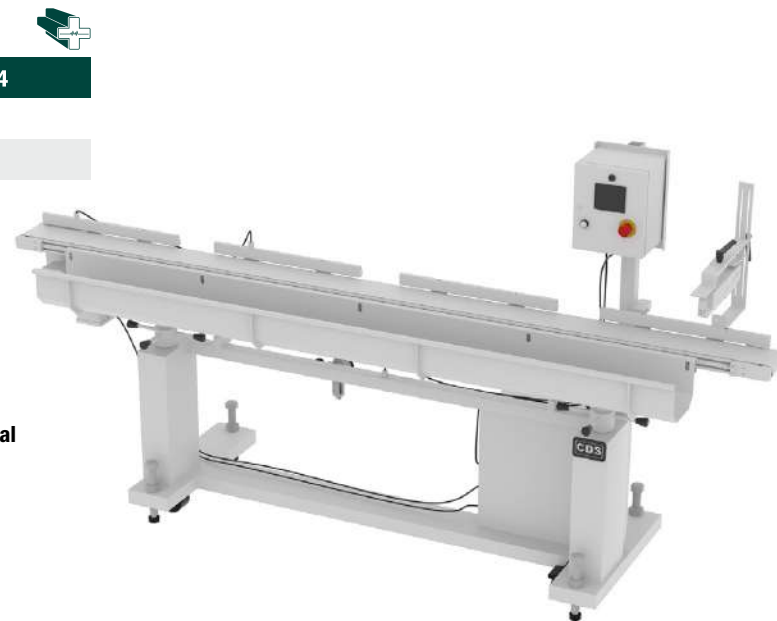

- ✓ Clean room ready
- ✓ Medical grade stainless steel collection tray
- ✓ FDA approved non-marking conveyor belt material

WINDERS

CDS' Winders efficiently collect small, delicate, and flexible extrusions such as medical and non-medical tubing and profiles.

AUTOMATIC COIL WINDERS

- Heavy-duty steel construction
- Adjustable inner coil diameter
- Coiler speed automatically synchronizes with line speed to maintain line tension
- Line direction: Right-Left/Left-Right

CAW SERIES

STANDARD FEATURES	CAW1	CAW2
Maximum Spool Diameter	54"	22"
Spool Width	24"	12"
Number of Spools	1	2

\*CAW: CDS Automatic Coil Winder



VERTICAL WINDERS

- Heavy-duty steel construction
- Inline reducer(s)
- Dancer system for line speed synchronization
- Line direction: Right-Left/Left-Right

\*CW: CDS Vertical Winder

Note: Different Vertical Winder configurations available upon request

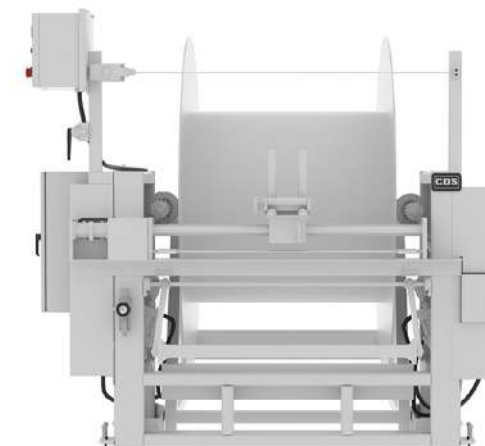

## REEL COILERS

CDS' Reel Coilers operate at the end of the extrusion line to coil or wind the finished product. There are different factors to consider when selecting the proper coiler for your application. Choosing the right coiler is important for easy integration and operation of your production line. CDS' customizable coilers provide the flexibility to support future changes in speed, productivity, and size ranges of the finished extrudate.

### REEL COILERS

- Heavy-duty steel construction
- Spool driven by heavy-duty gearbox
- Reels lifted mechanically
- Touch screen controls (HMI)
- Programmable recipes
- Line direction: Right-Left/Left-Right

\*CRC: CDS Reel Coiler

**Note:** Different Reel Coiler configurations available upon request

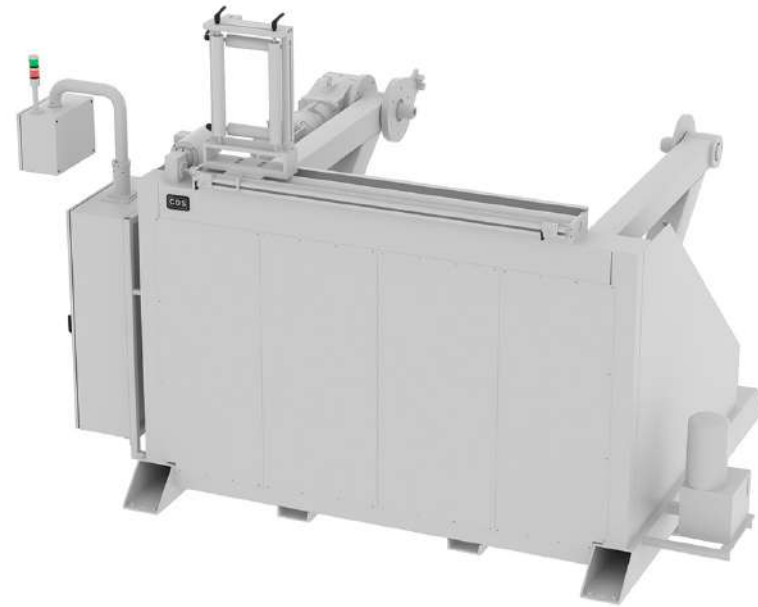

### REEL COILERS WITH COLLAPSIBLE CORES

- Heavy-duty steel construction
- Collapsible spool driven by heavy-duty gearbox
- Touch screen controls (HMI)
- Programmable recipes
- Line direction: Right-Left/Left-Right

\*CCRC: CDS Collapsible Reel Coiler

**Note:** Different Reel Coiler configurations available upon request

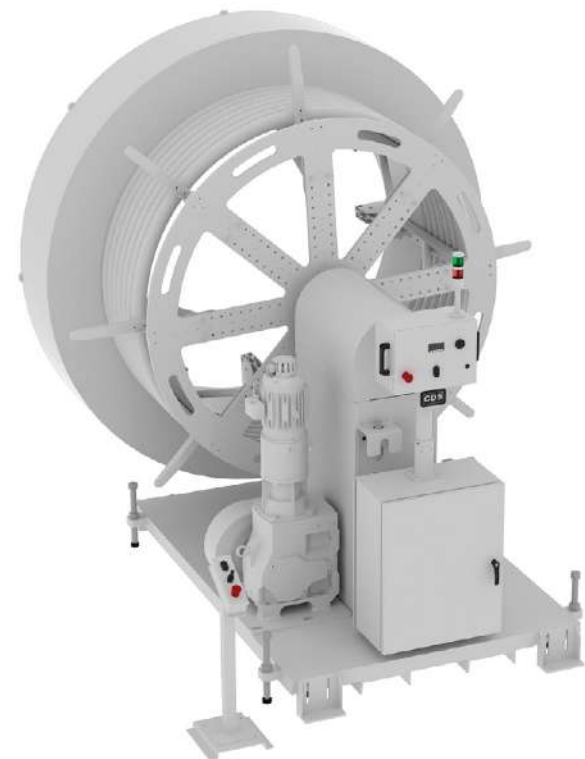
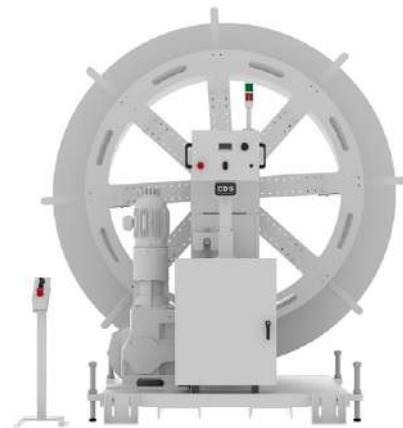

## PANNERS

CDS' Customizable Panning Systems provide low tension to precisely pan flexible rubber extrusions.

### COMBINATION HAUL-OFF/CRIMPER/CONVEYOR/PANNER

- Heavy-duty steel construction
- DuraGrip covered belts
- Both belts driven
- Driven crimper wheels
- Pneumatic chute system
- Panning speed automatically synchronizes with line speed to maintain proper tension
- Touch screen controls (HMI)
- Programmable recipes
- Line direction: Right-Left/Left-Right

**Note:** Combination Crimper/Cutter can be replaced by a Servo Fly-Knife

Cutter or a Servo Rotary Knife Cutter

Panning station can be manually operated

Guards can be designed according to operator interface

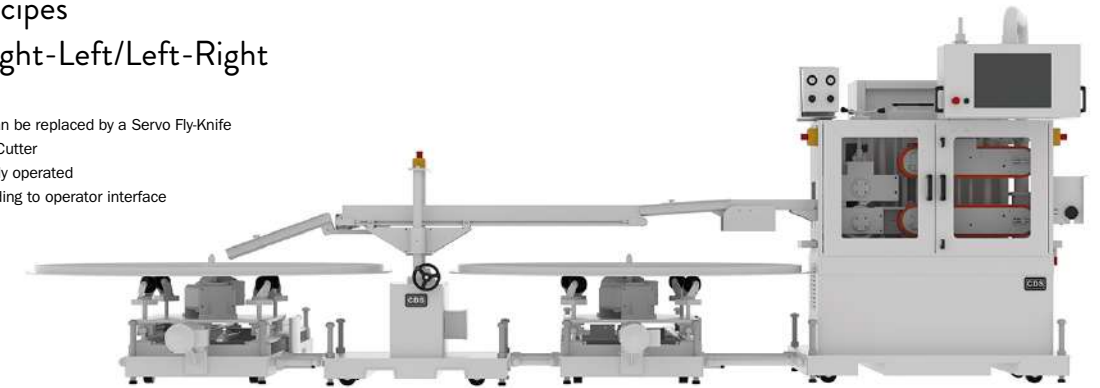

### PAY-OFFS

CDS' Pay-Offs operate at the start or the end of the extrusion line to uncoil the product and provide flexibility to support changes in speed, productivity, and size ranges of the products.

#### RIM PAY-OFFS

- Heavy-duty steel construction
- Single reel station pay-off
- Adjustable guides for different reels and flange thicknesses
- Mechanical or electronic dancer system for line speed synchronization
- Line direction: Right-Left/Left-Right

\*CRW: CDS Rim Pay-Off



**DRIVEN PAY-OFFS**

- Heavy-duty steel construction
- Customizable receiving area for different reel widths and diameters
- Mechanical or electronic dancer system for line speed synchronization
- Inline reducer(s)
- Line direction: Right-Left/Left-Right

\*CDPO: CDS Driven Pay-Off



**COLLECTION OPTIONS**

- Dual configuration
- Central greasing system
- Touch screen controls (HMI)
- Programmable recipes
- Allen Bradley, Omron, and Siemens packages available (\*)
- Line Integration: Hard-wired interconnection (analog microprocessor interface, speed signal to measuring device, encoder I/O), Ethernet/IP available
- UL-CSA-CE Certification

(\*\*): All motors are Energy-Efficient  
 (\*): Other brands are available upon request

**TAKEAWAY CONVEYOR OPTIONS**

- Discharge controlled by timer or sensor
- Customizable conveyor width and length
- Customizable collection area
- Customizable table width and bin type
- Pneumatic diverter or push arm
- Dual pneumatic part ejector system
- Electrics: 230-460-575VAC/3 PH/60 Hz, 380-400VAC/3 PH/50 Hz

**COLLECTION TABLE OPTIONS**

- Tilt action controlled by electronic timer, mechanical limit switch or photo-optic sensor (\*CTT/\*CTTP)
- Customizable pan width and length (\*CTT/\*CTTP)
- Customizable table width and length (\*CSM)
- Customizable collection area (\*CTT/\*CTTP)
- Customizable roller orientation and collection area (\*CRT/\*CRTP)
- Mobile cart (\*CTT)
- Pipe cart (\*CTTP)
- Electrics: 120VAC/1 PH/60 Hz, 220VAC/1 PH/50 Hz
- Electrics: 230-460-575VAC/3 PH/60 Hz, 380-400VAC/3 PH/50 Hz (\*CSM)

(\*CTT): Applicable only on Tilt Tables  
 (\*CTTP): Applicable only on Pipe Tilt Tables  
 (\*CSM): Applicable only on Stacking Machines  
 (\*CRT): Applicable only on Run-Off Tables  
 (\*CRTP): Applicable only on Pipe Run-Off Tables

**WINDER OPTIONS**

- Customizable receiving area for different reel widths and diameters (\*CRC/\*CW)
- Automatic traverse system
- Foot pedal activation
- Fixed or Collapsible core
- Loop control (electronic or mechanical)
- Forklift slots on frame
- Oscillation movement
- Electrics: 230-460-575VAC/3 PH/60 Hz, 380-400VAC/3 PH/50 Hz

(\*CRC): Applicable only on Takeaway Conveyors  
 (\*CW): Applicable only on Vertical Winders

**TEXTURIZING MACHINES**

CDS' Texturizing Machines are known for their Embossing Stands, which provide specialized product definition.

**EMBOSSING STANDS**

CDS' Embossing stands embed a repeated, customer-specified pattern into extruded material. A heating unit can be added for extruded applications that require heated rolls.

**CES SERIES**

STANDARD FEATURES	CES4	CES6	CES8	CES10
Roller Diameter	4"	4"	8"	10"
Roller Width	4"	6"	8"	10"

\*CES: CDS Free-Driven Embossing Stand

**Standard Specifications:**

- Full coverage safety enclosure
- Heavy-duty steel construction
- Manually adjustable bottom roll
- Adjustable entrance guide rollers
- Line direction: Right-Left/Left-Right

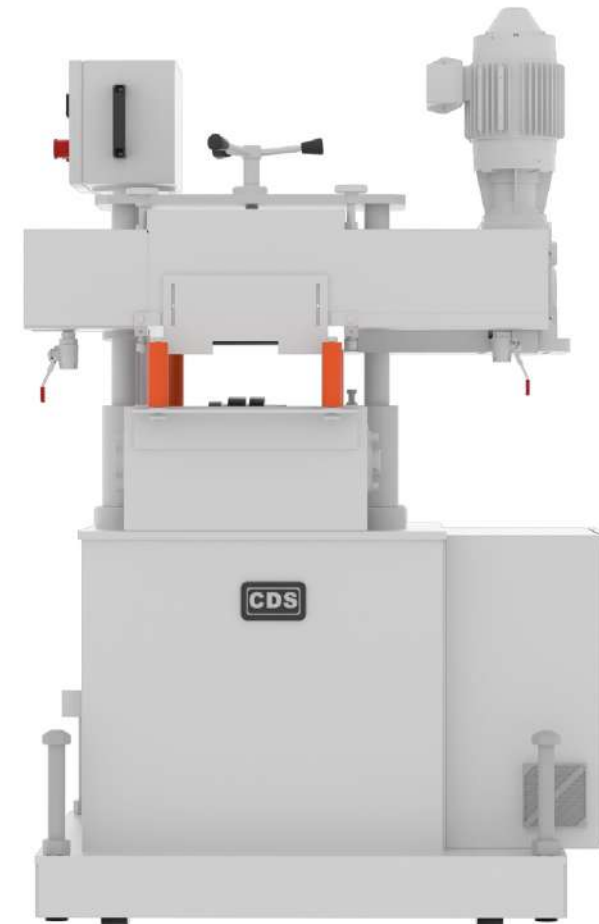

**CES1/CES2 SERIES**

STANDARD FEATURES	CES1-4	CES1-6	CES1-8	CES1-10	CES1-12	CES1-14	CES1-15	CES1-18	CES1-24
Roller Diameter	4"	4"	8"	10"	10"	8"	10"	10"	20"
Roller Width	4"	6"	8"	10"	12"	14"	15"	18"	24"

\*CES1: CDS Upper Driven Embossing Stand  
 \*CES2: CDS Upper/Lower Driven Embossing Stand

- ✓ **Pneumatic upper clamping control**
- ✓ **Inline reducer(s)**
- ✓ **Vector closed-loop electrical system with encoder feedback**

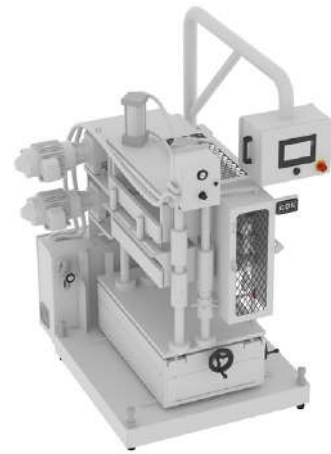
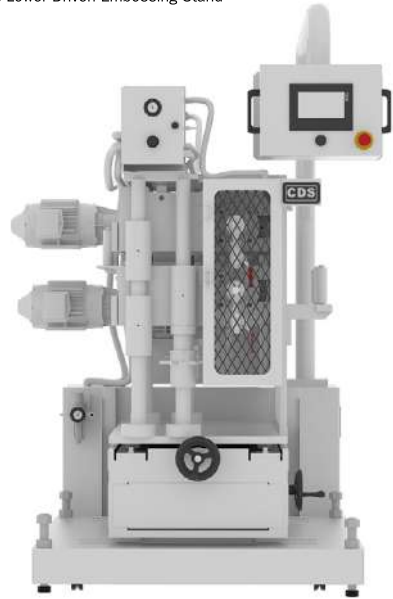

**TEXTURIZING OPTIONS**

- Dual configuration
- Oil or electric heating system and control (\*\*)
- Spare embossing blank/engraved oil or electric heated rolls
- Roller engraving
- Upper roll free-driven/Lower roll driven (\*CES1)
- Pneumatic upper clamping control (\*CES)
- Servo-motorized clamping control with touch screen controls (HMI) (\*CES1/\*CES2)
- Direct drive system with vector controls and motors (\*\*) (\*CES1/\*CES2)
- Direct drive system with servo controls, motors, and touch screen controls (\*\*) (\*CES1/\*CES2)
- Gap indicator
- Forklift slots on frame
- Touch screen controls (HMI)
- Programmable recipes
- Allen Bradley, Omron, and Siemens packages available (\*)
- Line Integration: Hard-wired interconnection (analog microprocessor interface, speed signal to measuring device, encoder I/O), Ethernet/IP available
- Electrics: 230-460-575VAC/3 PH/60 Hz, 380-400VAC/3 PH/50 Hz
- UL-CSA-CE Certification

(\*\*): All motors are Energy-Efficient  
 (\*CES): Applicable only on Free-Driven Embossing Stands  
 (\*CES1): Applicable only on Upper Driven Embossing Stands  
 (\*CES2): Applicable only on Upper/Lower Driven Embossing Stands  
 (\*): Other brands are available upon request

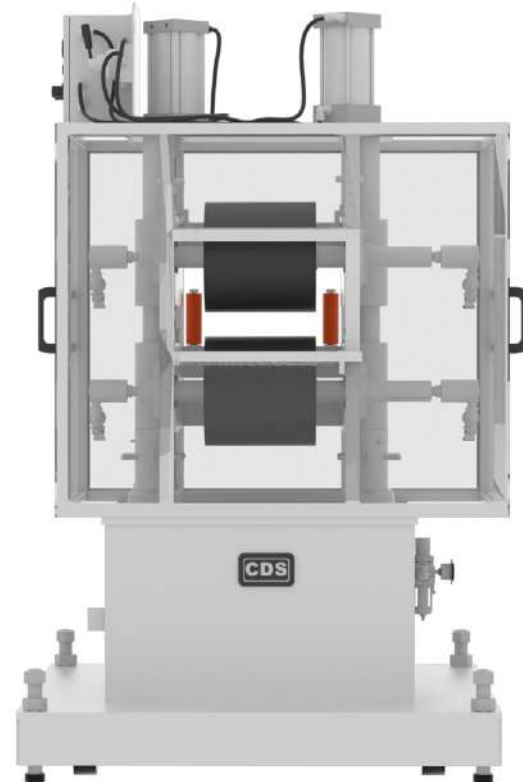

**AUXILIARY EQUIPMENT**

CDS strives to surpass its customers' expectations by providing custom Auxiliary Equipment to optimize your downstream extrusion line.

**AUXILIARY TANKS**

CDS' Auxiliary Tanks are the perfect addition to our Vacuum Calibration Tables by providing the necessary vacuum, spray, or flood cooling required for various profile extrusions.

**AUXILIARY VACCUM TANKS**

- Heavy-duty stainless steel tank construction
- Clear-view covers with hold-down latches
- Precision-aligned mounting rails
- Plastic spray nozzles top, side, and bottom mounted
- Vacuum level gauge and relief valve

\*CAVT: CDS Auxiliary Vacuum Tank



**Standard Specifications:**

- Clear-view covers with hold-down latches
- Bulkhead opening to suit product shape
- Water and/or vacuum entry ports
- Multiple drains with shut-off valves
- Line direction: Right-Left/Left-Right

Note: Different tank widths, heights, and lengths available

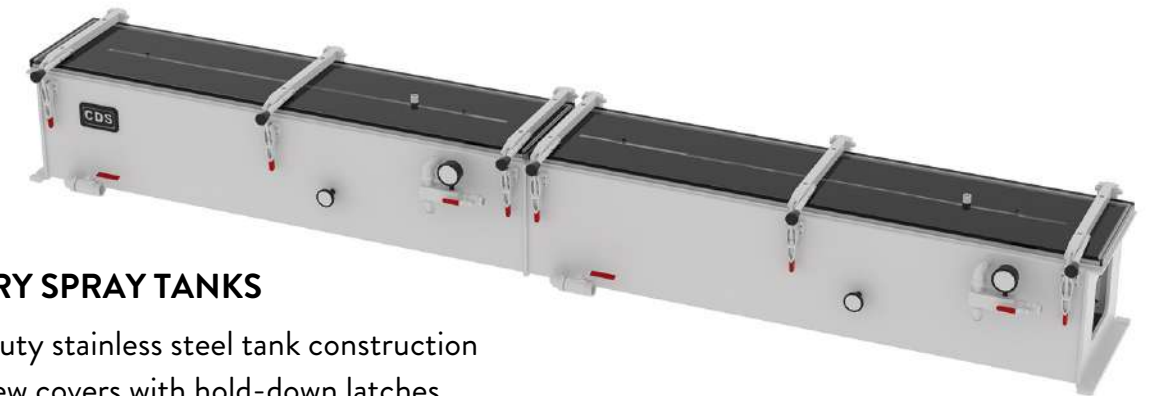

**AUXILIARY SPRAY TANKS**

- Heavy-duty stainless steel tank construction
- Clear-view covers with hold-down latches
- Stainless steel spray bars with quick-change spray nozzles
- Product support rollers

\*CAST: CDS Auxiliary Spray Tank





**AUXILIARY WATER TANKS**

- Heavy-duty stainless steel tank construction
- Open upper tank for easy start-up
- Copper spray bars for water turbulence
- Rotary/Manual stand pipes for water control
- Product support rollers

\*CAWT: CDS Auxiliary Water Tank



**VORTEX AUXILIARY VACUUM TANKS**

- Clear acrylic tank construction
- Clear-view covers with hold-down latches
- Precision machined side mounting slots
- Vacuum level gauge and relief valve

\*CVAT: CDS Vortex Auxiliary Vacuum Tank

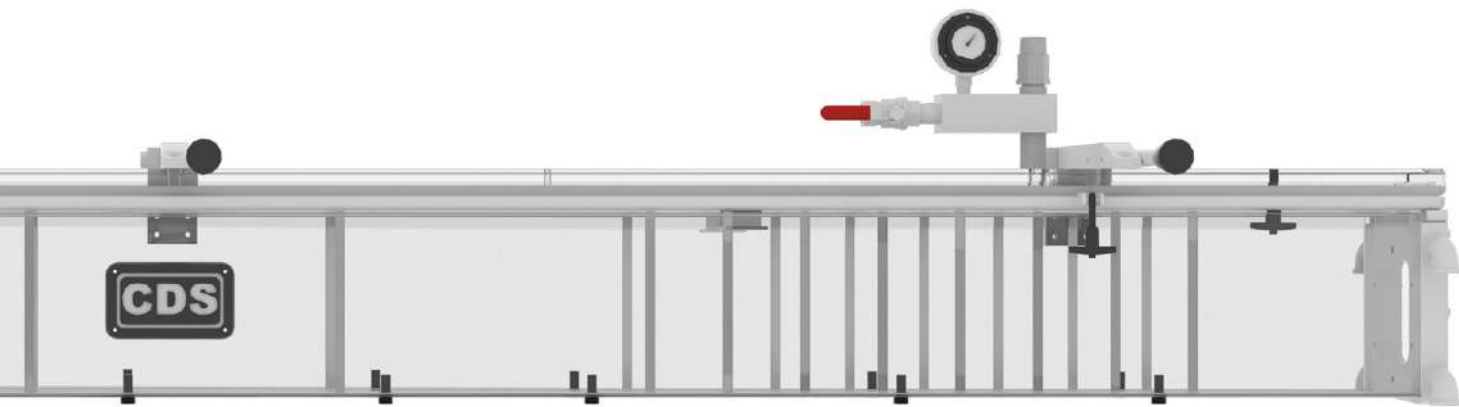

**AUXILIARY EQUIPMENT**

CDS' Auxiliary Equipment complements your extrusion line by providing additional support to your process requirements and improving the overall finished product quality.

**AUXILIARY VACUUM PUMP ASSEMBLY**

- Heavy-duty support base
- Air/Water separation reservoir
- Vacuum level gauge and relief valve
- Vacuum manifold with 8 outlets
- Available in 3, 5, 7.5, and 10 HP
- Line direction: Right-Left/Left-Right

\*CAVP: CDS Auxiliary Vacuum Pump Assembly

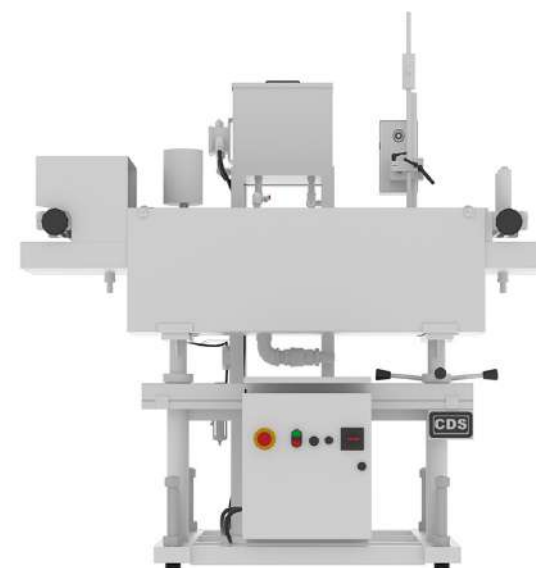
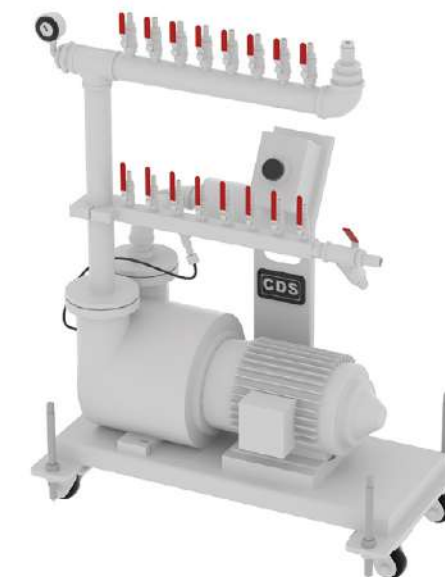

**LUBE TANKS**

- Heavy-duty steel construction
- Stainless steel upper tank and reservoir
- Lube recirculation system with pneumatic or electric pump
- Air wipe system
- Line direction: Right-Left/Left-Right

\*CLT: CDS Lube Tank

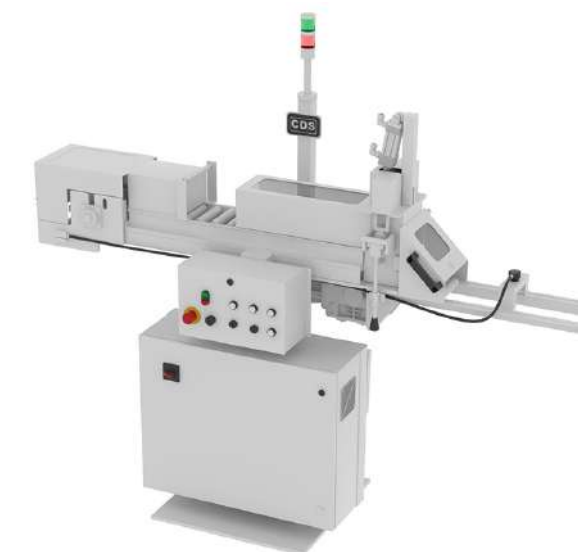

**STRIP FEEDERS**

- Heavy-duty steel construction
- Pneumatic clamping system
- Dancer system for line speed synchronization
- Driven/free-driven serrated rollers
- Inline reducer(s)
- Product detection alarm
- Line direction: Right-Left/Left-Right

\*CSFM: CDS Strip Feeding Machine



**PRE-HEATERS**

- Heavy-duty steel construction
- Compact stainless steel tunnel design
- Air blower heating system
- Insulated tunnel for heat retention
- Line direction: Right-Left/Left-Right

\*CPHM: CDS Pre-Heating Machine

Note: Infrared and Radiant Heater Ovens available upon request

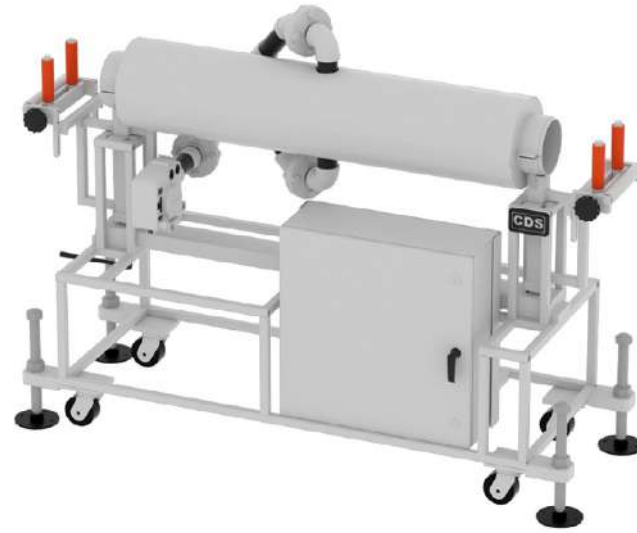

**START-UP WINCHES**

- Heavy-duty steel construction
- Safety shear pin for gearbox protection
- Direct drive system
- Pull force up to 10,000 lbs
- Integrated device to prevent winch strap from twisting
- Locking device for winch drum
- Line direction: Right-Left/Left-Right

\*CWCP: CDS Haul-Off Winch



**ULTRASONIC LOOP CONTROLS**

- Ease of loop adjustment
- Ultrasonic signal
- Low tension control
- Line direction: Right-Left/Left-Right

\*CULC: CDS Ultrasonic Loop Control



**TOOL AND DIE CLEANSING SYSTEM**

- Heavy-duty steel construction
- Stainless steel reservoir
- Recirculation pump up to 60 GPM
- Maximum water temperature 190°F
- Adjustable tooling die support
- Insulated tank walls
- Digital temperature controller
- Top hinged-covers

**INLINE ANNEALING TABLES**

- Heavy-duty steel construction
- Fully guarded for maximum machine operator safety
- Up to 400°F/204°C exposed surface temperature
- Adjustable opening
- Temperature controllers
- Touch screen controls (HMI)
- Line direction: Right-Left/Left-Right

\*CIAT: CDS Inline Annealing Table

Note: Different lengths and widths available upon request

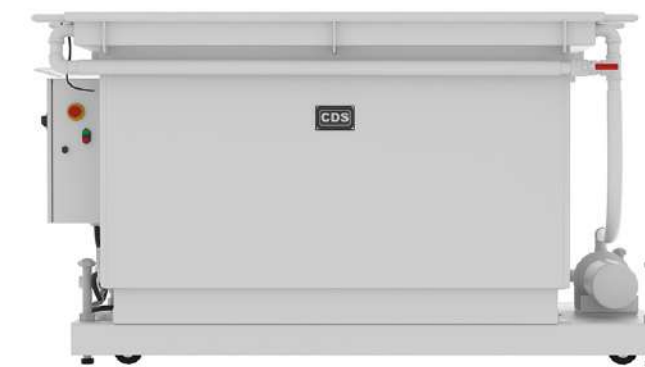

**AUXILIARY EQUIPMENT OPTIONS**

- Customizable configuration
- Forklift sots on frame (Not applicable on Auxiliary Tanks)
- Wireless remote control device (\*CWCP)
- Touch screen controls (HMI) (Not applicable on Auxiliary Tanks)
- Programmable recipes (Not applicable on Auxiliary Tanks)
- Allen Bradley, Omron, and Siemens packages available (\*)
- Line Integration: Hard-wired interconnection (analog microprocessor interface, speed signal to measuring device, encoder I/O, Ethernet/IP available (Not applicable on Ultrasonic Loop Controls))
- Electrics: 230-460-575VAC/3PH/60 Hz, 380-400VAC/3PH/50 Hz
- UL-CSA-CE Certification

(\*\*) All motors are Energy-Efficient

(\*CWCP): Applicable only on Haul-Off Winches

(\*): Other brands available upon request



## OUR SOLUTIONS

Since 1997, CDS has been designing downstream extrusion machinery for different markets including profiles, pipes, rubber, automotive, tubes, medical, and engineering plastics that meet the specific market and customer requirements.

CDS ensures our machines are designed all the features required for manufacturing high performance products.

- ✓ Machinery installed, tested and proven by thousands of customers.
- ✓ Thousands of downstream machinery in operation in North America and abroad.
- ✓ Premium quality off-the-shelf components chosen by satisfied and loyal suppliers for more than two decades.

We are constantly innovating our models, designs, and accessories to give our customers a competitive advantage in the different downstream extrusion markets.



## PROFILES

CDS' Profile Machinery can be used in any consumer or industrial application, with a wide array of materials including thermoplastics and rubbers. You can rely on our skilled production team to engineer, design, and manufacture your next downstream extrusion system.

### OUR TECHNOLOGY

Line Automation

Energy-Efficient Vacuum Calibration Systems



Chipless Cutting

High-Precision Pullers

### OUR APPLICATIONS

Our machinery can process extruded profiles from various materials most commonly PVC and RPVC for the following applications:

- Window and door profiles
- Fencing profiles
- Technical profiles
- Panel profiles

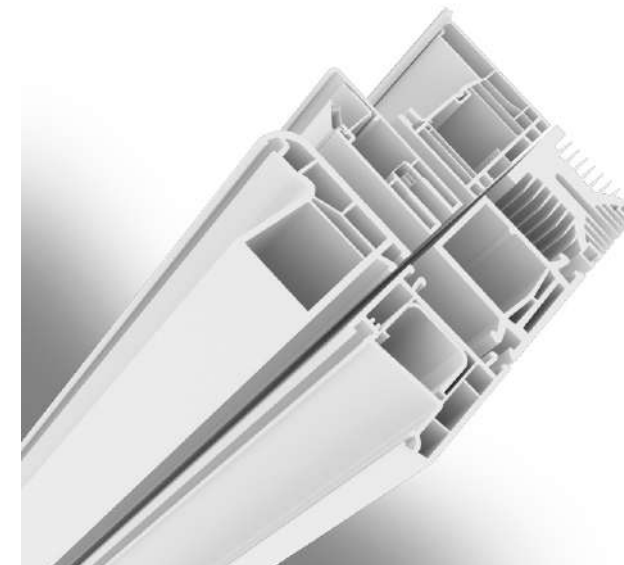

### OUR PROFILE EQUIPMENT

#### PROFILE COOLING MACHINES

- Vacuum Calibration Tables
- Energy-Efficient Vacuum Calibration Tables

#### PROFILE PULLING MACHINES

- Belt Haul-Offs
- Cleat Haul-Offs

#### PROFILE CUTTING MACHINES

- Traveling Cut-Off Saws
- Cross-Cut Saws
- Traveling Chipless Hot Blades

#### PROFILE COMBINATION UNITS

- Cleat Haul-Off/Traveling Cut-Off Saw
- Cleat Haul-Off/Traveling Chipless Hot Blade

#### PROFILE COLLECTION MACHINES

- Tilt Tables
- Run-Off Tables



## PIPES

CDS' Pipe Systems will surpass your expectations, since we design and build cost-efficient and reliable equipment according to your specific requirements. From automation to energy efficiency, we follow the latest technological trends to maximize your production and improve your output.

### OUR TECHNOLOGY

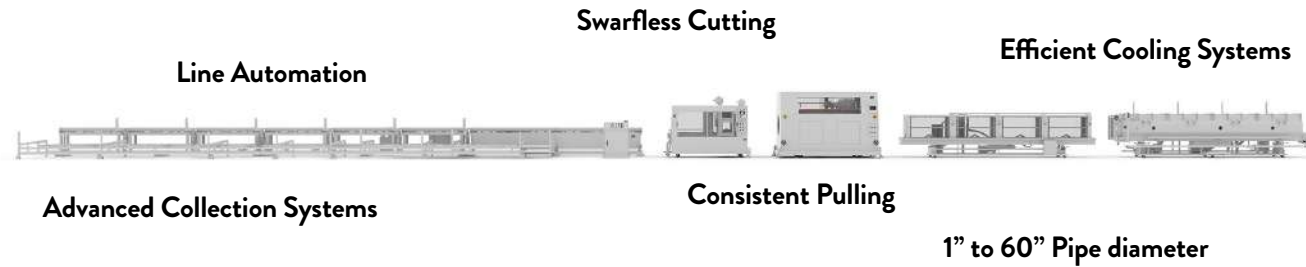

### OUR APPLICATIONS

Our machinery can process extruded pipes from various materials, including **PVC, CPVC, HDPE, LDPE, PP, and Nylon** for the following applications:

- Water pipes
- Drinking water pipes
- Sewage and drainage pipes
- Electrical conduits
- Gas pipes
- PEX pipes
- Irrigation tubes
- Cable ducts

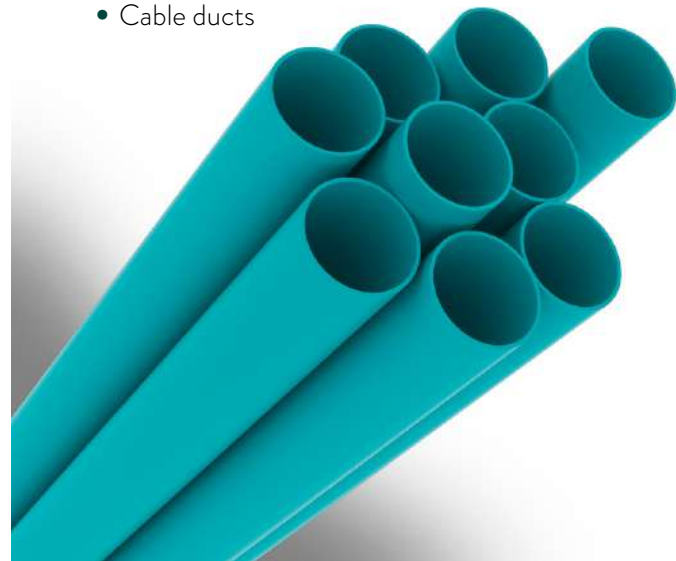

### OUR PIPE EQUIPMENT

#### PIPE COOLING MACHINES

- Vacuum Spray Sizing Tanks
- Spray Cooling Tanks

#### PIPE PULLING MACHINES

- Belt Haul-Offs
- Cleat Haul-Offs
- Pipe Haul-Offs

#### PIPE CUTTING MACHINES

- Traveling Planetary Saws
- Traveling Cut-Off Saws
- Servo Rotary Knife Cutters
- Swarfless Cutters

#### PIPE COLLECTION MACHINES

- Tilt Tables
- Run-Off Tables
- Reel Coilers

#### PIPE AUXILIARY EQUIPMENT

- Start-Up Winches

## RUBBER

CDS' Rubber Machinery offers a wide range of possibilities and our expertise enables us to accommodate diverse custom applications of such plastic alternatives.

### OUR TECHNOLOGY

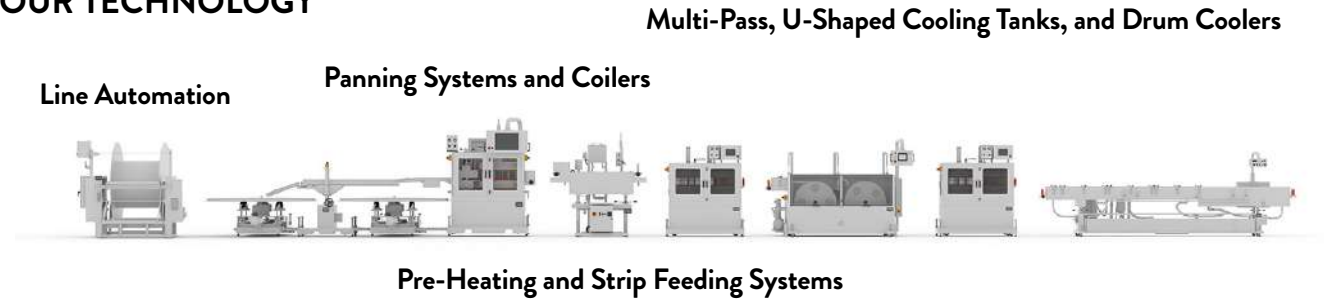

### OUR APPLICATIONS

Our machinery can process extruded rubber profiles and tubes from various materials, including **Ethylene Propylene (EPDM), Neoprene, Silicone, and Styrene-butadiene rubber (SBR)** for the following applications:

- Customized rubber profiles
- Rubber tubes
- Flexible to semi-flexible and rigid profiles or tubes
- Reinforced rubber

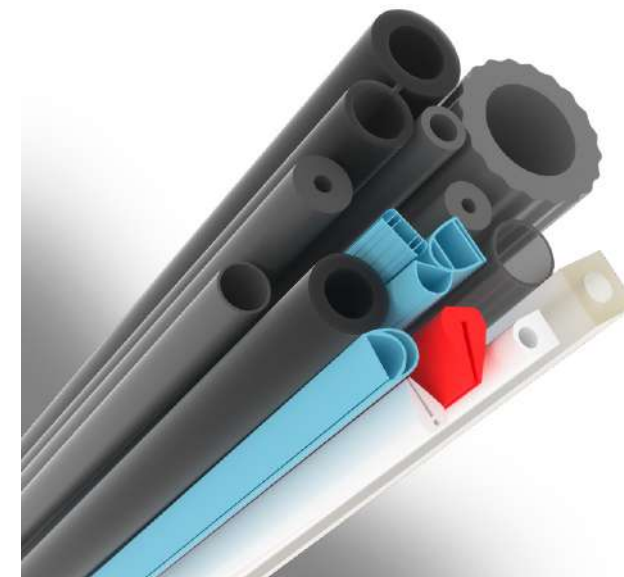

### OUR RUBBER EQUIPMENT

#### RUBBER COOLING MACHINES

- Cooling Tanks
- Multi-Pass Drum Coolers

#### RUBBER PULLING MACHINES

- Belt Haul-Offs
- Horizontal Belt Haul-Offs

#### RUBBER CUTTING MACHINES

- Servo Fly-Knife Cutters
- Servo Rotary Knife Cutters
- Traveling Guillotine Cutters

#### RUBBER COMBINATION UNITS

- Belt Haul-Off/Servo Fly-Knife Cutter
- Belt Haul-Off/Servo Rotary Knife Cutter
- Belt Haul-Off/Chop Saw

#### RUBBER COLLECTION MACHINES

- Takeaway Conveyors
- Automatic Coil Winders
- Panners and Pay-Offs

#### RUBBER AUXILIARY EQUIPMENT

- Pre-Heaters
- Strip Feeders
- Ultrasonic Loop Controls
- Lube Tanks



## AUTOMOTIVE

CDS' Production Team will provide valuable insight to any Automotive Downstream Extrusion System. Each machine is manufactured with precision and state-of-the-art workmanship to ensure optimal performance and reliability.

### OUR TECHNOLOGY

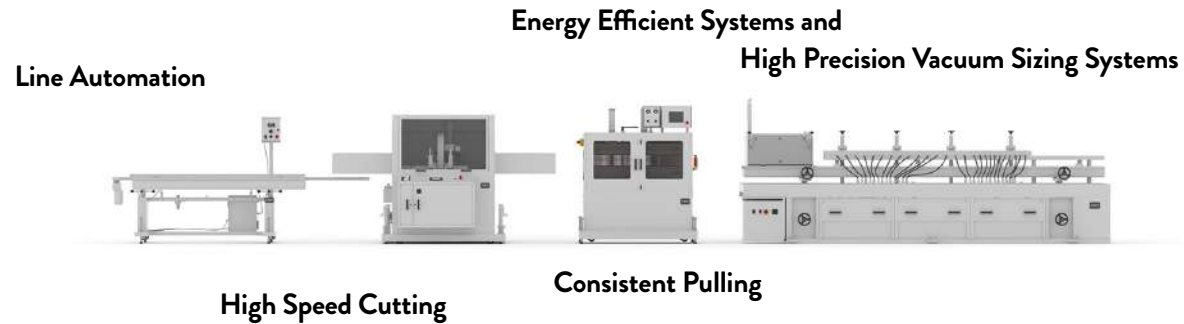

### OUR APPLICATIONS

Our machinery can process extruded automotive profiles and tubes from various materials, including **PEBAX, PA, HDPE, FPVC, TPE, FEP, TPU, and THV** for the following applications:

- Flexible
- Semi-flexible
- Reinforced automotive profiles or tubes

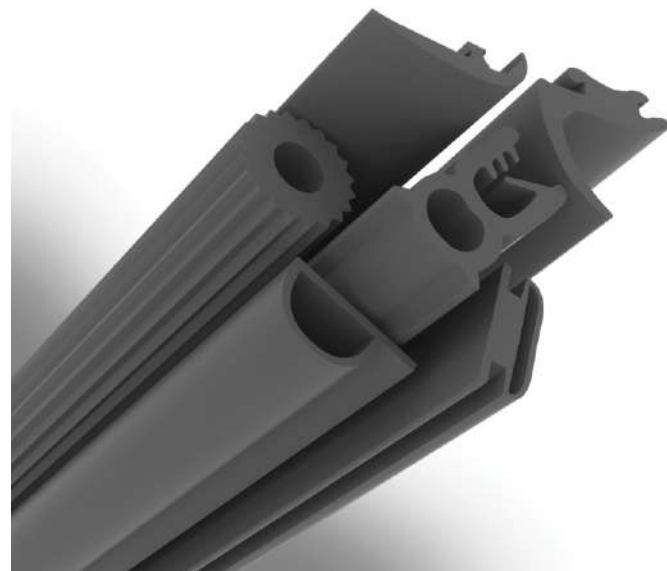

### OUR AUTOMOTIVE EQUIPMENT

#### AUTOMOTIVE COOLING MACHINES

- Vacuum Calibration Tables
- High-Precision Vacuum Sizing Tanks
- Water Cooling Tanks

#### AUTOMOTIVE PULLING MACHINES

- Belt Haul-Offs
- Horizontal Belt Haul-Offs

#### AUTOMOTIVE CUTTING MACHINES

- Servo Saws
- Servo Cutters
- Traveling Guillotine Cutters

#### AUTOMOTIVE COMBINATION UNITS

- Belt Haul-Off/Servo Fly-Knife Cutter
- Belt Haul-Off/Servo Rotary Knife Cutter
- Belt Haul-Off/Chop Saw

#### AUTOMOTIVE COLLECTION MACHINES

- Takeaway Conveyors

#### AUTOMOTIVE AUXILIARY EQUIPMENT

- Pre-Heaters
- Lube Tanks

## TUBES

Accompanied by unparalleled expertise, CDS' Tube Downstream Extrusion Machinery is our most competitive line. Machine applications are engineered according to the elasticity, abrasion and tear strength of your materials and processes.

### OUR TECHNOLOGY

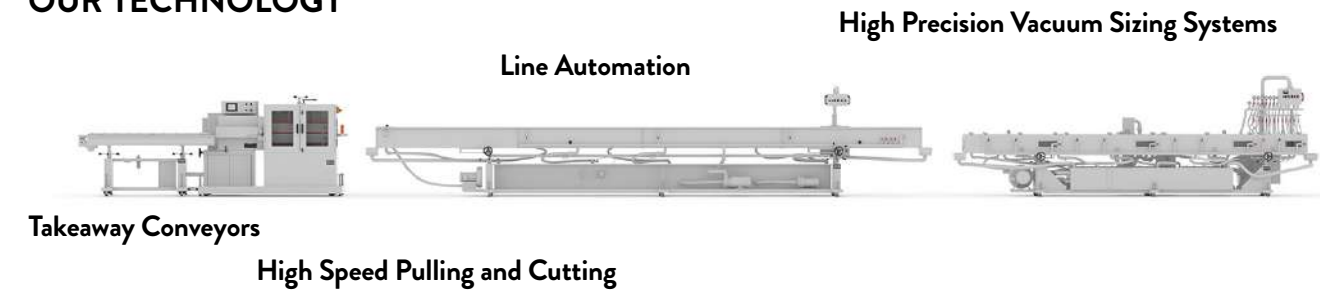

### OUR APPLICATIONS

Our machinery can process extruded tubes from various materials, including **RPVC, FPVC, PE, PP, ABS, PS, HIPS, Nylon, Polycarbonate, and other materials** for the following applications:

- Industrial hoses
- Food processing
- Healthcare
- HVAC industry
- Printing, packaging, and textile
- Traffic management
- Agricultural and construction
- Chemical and petrochemical industrials
- Sports and leisure



### OUR TUBE EQUIPMENT

#### TUBE COOLING MACHINES

- High-Precision Vacuum Sizing Tanks
- Spray Cooling Tanks
- Water Cooling Tanks

#### TUBE PULLING MACHINES

- Belt Haul-Offs
- Tube/Pipe Haul-Offs

#### TUBE CUTTING MACHINES

- Saws
- Cutters

#### TUBE COMBINATION UNITS

- Belt Haul-Off/Fly-Knife Cutter
- Belt Haul-Off/Servo Rotary Knife Cutter
- Belt Haul-Off/Chop Saw

#### TUBE COLLECTION MACHINES

- Takeaway Conveyors
- Tilt Tables
- Automatic Coil Winders
- Reel Coilers



## MEDICAL

CDS' Medical Extrusion Systems are designed for consistent accuracy and precision. Built of medical grade stainless steel according to the industry standards, they may be used in a clean room environment for easy maintenance.

### OUR TECHNOLOGY

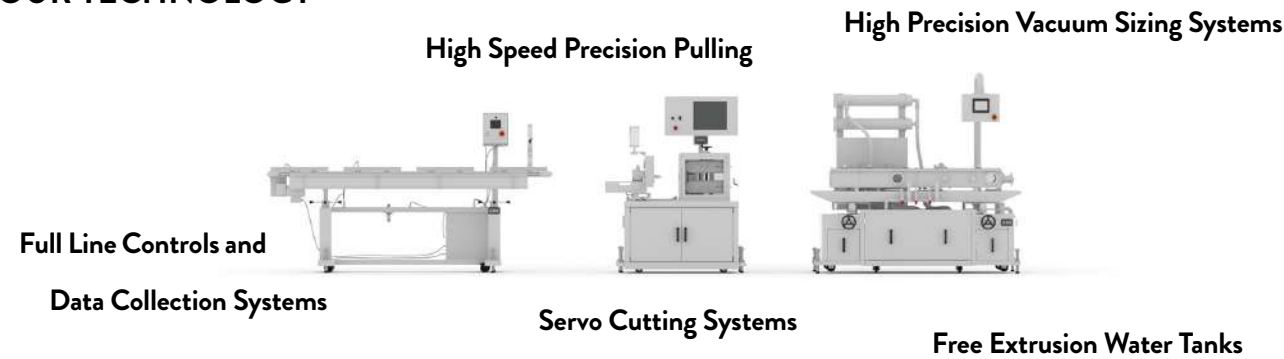

### OUR APPLICATIONS

Our machinery can be customized to meet the specialized requirements of the medical tubing industry and can process extruded medical tubes from various materials, including: **PEBAX, PA, FPVC, TPE, FEP, TPU, EVA, PP, and PE** for the following applications:

- Catheters
- Drainage tubes
- Drug delivery
- Bump tubing (Implanted tubing)

### OUR MEDICAL EQUIPMENT

#### MEDICAL COOLING MACHINES

- Medical High Precision Vacuum Sizing Tanks
- Medical Water Cooling Tanks
- Medical Free Extrusion Water Tanks
- Medical Multi-Pass Water Cooling Tanks

#### MEDICAL PULLING MACHINES

- Medical Belt Haul-Offs
- Medical Roll Haul-Offs

#### MEDICAL COMBINATION UNITS

- Medical Belt Haul-Off/Servo Fly-Knife Cutter

#### MEDICAL COLLECTION MACHINES

- Medical Takeaway Conveyors

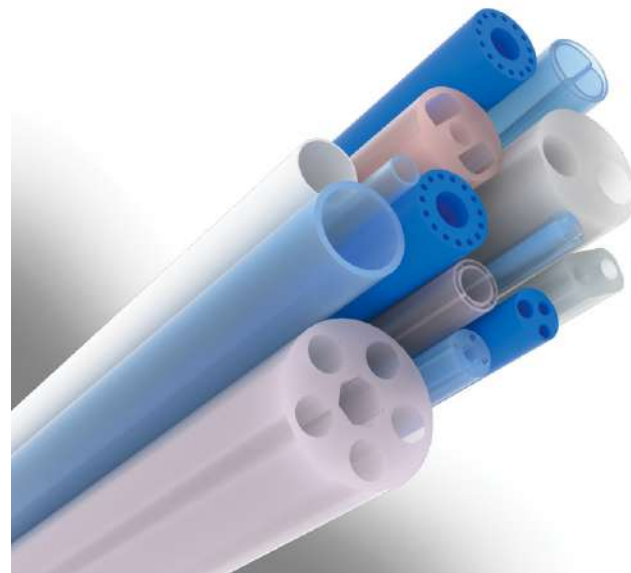

## ENGINEERING PLASTICS

CDS' Machinery is equipped to handle Engineering Plastics for your most demanding applications. Our machines are built with the necessary hydraulics, programming, and safety features for solid construction and efficient production. Customize your machinery for appropriate heat resistance, mechanical strength, rigidity, chemical stability, and flame retardants.

### OUR TECHNOLOGY

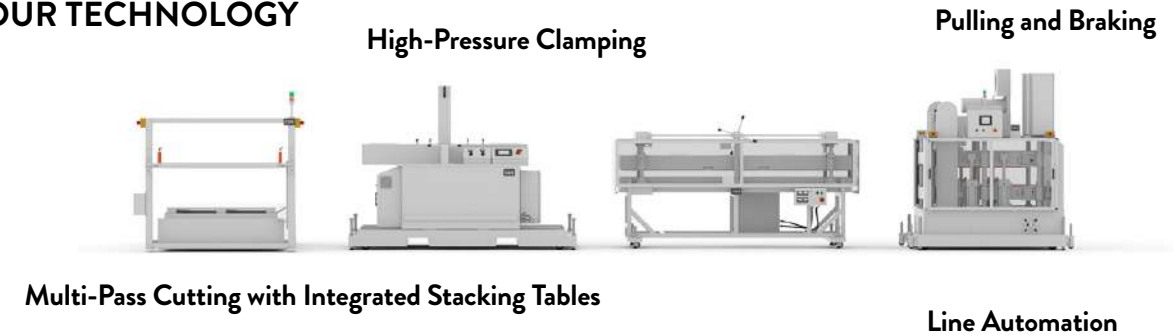

### OUR APPLICATIONS

Our machinery can process extruded slabs, tubes, and rods from different materials, including **PE, PETFE, PVC, PP, Nylon, Acetal, Delrin, Peek, and other similar materials** for the following applications:

- Aerospace
- Oil and gas
- Health care
- Food processing
- Transport
- Pharmaceutical



### OUR ENGINEERING PLASTICS EQUIPMENT

#### ENGINEERING PLASTICS PULLING MACHINES

- Slab/Rod Haul-Off Brakes
- Tube/Rod Haul-Off Brakes

#### ENGINEERING PLASTICS CUTTING MACHINES

- Cross-Cut Saws
- Multi-Pass Cross-Cut Saws
- Traveling Planetary Saws

#### ENGINEERING PLASTICS COLLECTION MACHINES

- Tilt Tables
- Stacking Tables
- Run-Off Tables

#### ENGINEERING PLASTICS AUXILIARY EQUIPMENT

- Inline Annealing Tables

## SERVICES

CDS is renowned for its expertise and efficient post-sale customer service. Our priority is your productivity and our goal is to ensure your full satisfaction.

CDS has a tradition of backing great products with great service. We respond quickly and efficiently to all service-related requests:



### 1) REPAIRS AND REBUILDS

Our Service department is there for any repairs you may need to optimize the performance of your equipment. Is something not working right? Tell us what's wrong. We most likely have the solution!

Be it remanufacturing, rebuilding or overhauling, we offer this service with a single objective: to make your machine work again at the same or higher level of productivity as before.

### WHY REFURBISH WITH CDS?

- ✓ Improves the market value of defective or damaged equipment
- ✓ Offers a high return on capital equipment investments
- ✓ Maximizes equipment efficiency and performance by adding new components and accessories
- ✓ Eliminates the process of identifying, comparing, and acquiring new capital equipment
- ✓ Allows the equipment to accommodate component upgrades according to current industry standards
- ✓ Minimizes training that operators would need for new machinery



### 2) TECHNICAL SUPPORT

We know our machines best. This means that the CDS Service Department is your best resource for technical support and/or troubleshooting your equipment. You get the best possible support with a quick consultation on any issue or operational problem. Our field technicians are also available for on-site support.



### 3) PARTS

Whether it's a missing, defective or worn-out component or accessory, we can replace it. Optimize and prolong the life of your machine by selecting from CDS' vast array of brand name and factory-built replacement parts. All parts come in many different sizes, grades, and types.



### 4) START-UP AND TRAINING

Not sure where to start once you have acquired brand new machinery? No problem! CDS understands how important it is to start on the right foot and we want you to be fully productive from the get-go.

CDS' machinery is shipped with machine-specific user manuals, including main operations, functions, technical documents, and safety features. If you need extra support for your machine operation, we can help you! CDS offers training sessions with our experienced technicians to make sure that you fully understand your equipment.



### 5) SAFETY UPGRADES

CDS manufactures reliable equipment for optimal performance and safe operations. Prevention is the key to avoiding serious injuries, ensuring all safety standards are followed. Since local safety standards vary from one province or state and country to another, it is important to be familiar with the local laws.

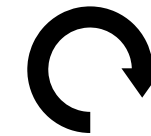

### 6) PREVENTIVE MAINTENANCE

Preventive maintenance is essential to extend your equipment's life. It ensures the equipment not only lasts longer, but also to maintain proper tolerances for your production requirements.

### CDS HAS YOUR BACK COVERED WITH ITS PROFESSIONAL AND EFFICIENT AFTER SALE SERVICES



#### SERVICE & SUPPORT (24 HRS)

E-mail: [service@cdsmachines.com](mailto:service@cdsmachines.com)  
(514) 633-5933 Ext. 241



#### COMMENTS

E-mail: [info@cdsmachines.com](mailto:info@cdsmachines.com)  
(514) 633-5933 Ext. 315



#### REPLACEMENT PARTS

E-mail: [parts@cdsmachines.com](mailto:parts@cdsmachines.com)  
(514) 633-5933 Ext. 241

Do you have a problem with your machinery? Concerns? Questions?  
Call us anytime. Our service lines are open 24/7.



# CUSTOM DOWNSTREAM EXTRUSION SOLUTIONS



EASE OF  
OPERATION



ROBUST  
MACHINERY



COMPETITIVE  
LEAD TIMES



RELIABLE  
PERFORMANCE



QUALITY  
CONSTRUCTION



LONG-LASTING  
ENGINEERING



CUSTOMIZATION

*Our expertise is demonstrated  
in our process knowledge  
and the flexibility of our engineering,  
manufacturing, and service capabilities.*



CUSTOM DOWNSTREAM SYSTEMS

1930 52<sup>nd</sup> Avenue, Lachine (Quebec) H8T 2Y3, Canada

Telephone: +1.514.633.5933 • Fax: +1.514.633.5944

info@cdsmachines.com • cdsmachines.com